



**Address:-** Sector 130, Shastri Garhi Shahpur, Noida,  
Uttar Pradesh- 201304  
**Mob:-** +91 - 981187005, 9711966037, 9711966066  
**Email:-** seereba@seereba.com, sales@seereba.com  
**Website:-** www.seereba.com

Your Global Automation Partner

# TURCK

## The Full Range For Pressure Sensors



# A Global Leader in Industrial Automation

Turck's sensors, connectivity, and fieldbus technology products are built to be the best. As one of the most **prominent** sensor manufacturers **in the world**, we even back our sensors with a **lifetime warranty**. Turck works by bringing **rugged engineering** solutions to your industrial automation applications.

85,000+

Pioneer in non-contact

sensing

technology

Developed innovative **connectivity** solutions in response to our customers' needs

Recognized the need for advanced **I/O solutions** in harsh duty environments

**SUPPORT &** DEDICATED SERVICE

EXTENSIVE WARRANTY



4,800+  
APPLICATION EXPERTS

RESPOND and SOLVE over 1,200 inquiries per day

50+  
YEARS OF INNOVATION

2,000+

EXPERIENCED

SALES REPRESENTATIVES



Strategically placed manufacturing facilities in the

USA with **30** GLOBAL SUBSIDIARIES

GLOBAL BUT LOCAL...

60 representations worldwide



**Address:-** Sector 130, Shastri Garhi Shahpur, Noida, Uttar Pradesh- 201304

**Mob:-** +91 - 981187005, 9711966037, 9711966066

**Email:-** seereba@seereba.com, sales@seereba.com

**Website:-** www.seereba.com



**Address:-** Sector 130, Shastri Garhi Shahpur, Noida,  
Uttar Pradesh- 201304  
**Mob:-** +91 - 981187005, 9711966037, 9711966066  
**Email:-** seereba@seereba.com, sales@seereba.com  
**Website:-** www.seereba.com

# Content

<b>1. Pressure Sensing</b>	<b>04</b>
<b>2. Product Comparison Guide</b>	<b>05</b>
<b>3. Sensors</b>	<b>07</b>
PS+SeriesProgrammablePressureSensors PS	07
Series Programmable Pressure Sensors PK Series	09
Programmable Pressure Switches PT1000/2000	11
Pressure Switch PT1000 Series Pressure	13
Transmitters PT2000 Series Pressure Transmitters	15
PT1500 Milibar Pressure Transmitter PT1100	17
Mobile Equipment Pressure Transmitters PT2100	19
Mobile Equipment Pressure Transmitters PT1	21
Series Pressure Transmitters	23
	25
<b>4. Accessories</b>	<b>27</b>
ProcessConnection Adaptors	27
Protective Adaptors	28
Mounting Adaptors	28
<b>5. Diaphragm Seal Selection</b>	<b>29</b>
AssemblyPartNumbers	29
Fully Welded Diaphragms	30
Three Piece Assembled Diaphragms	30
Fully Welded Diaphragms With Clean Out	31
Flush Mount Diaphragms	31
Sanitary Diaphragms	32
<b>6. Application Considerations</b>	<b>33</b>
SizingPressure Sensors	33
Pressure Units	33
Pressure Units Conversion Chart	33
Pressure Sensor Measurement Types	33
Sensor References	34
Sensor Accuracy	35
Temperature Effects On Accuracy	35
Measuring Liquid Level With A Pressure Sensor	37
Fluid Column Height In PSI	37
Over Pressure And Burst Pressure	38
Pressure Spikes And Transients	38
Calibration NIST Certificates	39
High Temperature Applications	39
Process Connections	40
<b>7. Glossary Of Terms</b>	<b>41</b>
<b>8. Notes</b>	<b>46</b>

# Pressure Sensing

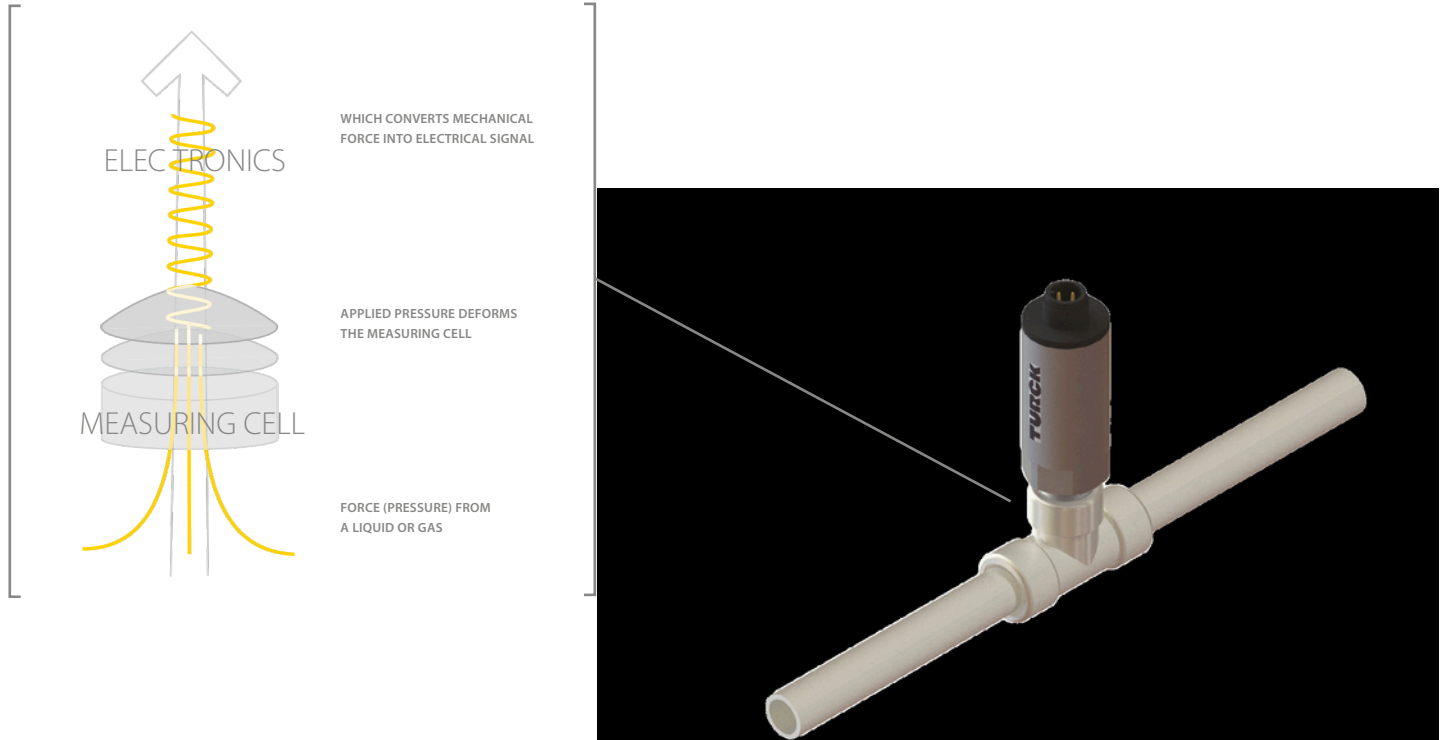

Fig. 1

Pressure is all around us. Most people don't think about it much, but it's something the manufacturing and industrial worlds deal with on a daily basis. A large portion of the machines out in industry utilize at least one form of fluid power.







Fluid power is a general term that can refer to gas or liquid. A gas would be defined as an air-like fluid substance which expands freely to fill any space available, irrespective of its quantity; a liquid is a substance that flows freely but is of constant volume, having a consistency like that of water or oil. Pneumatic systems utilize gases, while hydraulic systems utilize liquids.

Many fluid power systems, either hydraulic or pneumatic, have to be monitored for pressure. There are many ways to detect pressure, and the most common is a Bourdon tube gauge. Every gauge has the potential to be a pressure sensor. A pressure sensor has a measuring cell that converts (or transduces) the mechanical strain

of the pressure applied and converts the force into an electrical signal (Fig. 1). Pressure in a pipe, hose, or duct applies force on the measuring cell of a sensor, causing a deflection which is measured by an electrical circuit. This measurement is then converted into a current or voltage output.

Pressure sensors can be used in many different types of applications, from pressure monitoring to level and flow detection. The latter sections of this guide go into further detail regarding the application considerations to be aware of when utilizing a pressure sensor.

# Product Comparison Guide

	Features	Page
 <p><b>PS+ Programmable Pressure Sensor with Digital Display</b></p>	<ul style="list-style-type: none"> <li>■ Stainless steel measuring cell for pressure ranges &gt;10bar</li> <li>■ Up to 600 bar relative pressure</li> <li>■ Accuracy up to 0.25%</li> <li>■ IO-Link 1.1</li> <li>■ Automatic signal detection</li> <li>■ Up to seven-fold overpressure resistance</li> <li>■ High protection class (IP6K6K, IP6K7, IP6K9K)</li> <li>■ 180° invertible multi-color display</li> <li>■ Rotatable sensor body</li> <li>■  <b>IO-Link</b></li> </ul>	7
 <p><b>PK Programmable Pressure Switch with Digital Display</b></p>	<ul style="list-style-type: none"> <li>■ Fully programmable output, display units, and output functionality</li> <li>■ Pneumatic applications only</li> <li>■ Process connection NPT 1/8</li> <li>■ M8x1 Picofast electrical connection</li> <li>■ Two pressure ranges available: -1 to 0 Bar and 0 to 10 Bar</li> </ul>	11
 <p><b>PT1000/2000 Pressure with IO-Link</b></p>	<ul style="list-style-type: none"> <li>■ Programmable set points via IO-Link</li> <li>■ Rugged 303 stainless steel housing</li> <li>■ NPT and G (BSPP) process connections</li> <li>■ Ranges up to 600 Bar</li> <li>■  <b>IO-Link</b></li> </ul>	13
 <p><b>PT1000 OEM Pressure Transmitter</b></p>	<ul style="list-style-type: none"> <li>■ Ceramic measuring elements</li> <li>■ 316 stainless steel housing with Polyarylamide 50% GF electrical connector</li> <li>■ NPT, G (BSPP), and SAE-ORB process connections</li> <li>■ Gel filled housing for increased protection from water ingress</li> <li>■ Ranges up to 60 Bar</li> </ul>	15
 <p><b>PT2000 OEM Pressure Transmitter</b></p>	<ul style="list-style-type: none"> <li>■ 316 welded stainless steel measuring element</li> <li>■ 316 stainless steel housing with Polyarylamide 50% GF electrical connector</li> <li>■ NPT, G (BSPP), and SAE-ORB process connections</li> <li>■ Gel filled housing for increased protection from water ingress</li> <li>■ Ranges up to 1000 Bar</li> </ul>	17



**Address:-** Sector 130, Shastri Garhi Shahpur, Noida, Uttar Pradesh- 201304





**Mob:-** +91 - 981187005, 9711966037, 9711966066

**Email:-** seereba@seereba.com, sales@seereba.com

**Website:-** www.seereba.com



**Address:-** Sector 130, Shastri Garhi Shahpur, Noida, Uttar Pradesh- 201304  
**Mob:-** +91 - 981187005, 9711966037, 9711966066  
**Email:-** seereba@seereba.com, sales@seereba.com  
**Website:-** www.seereba.com

		Features	Page
	<b>PT1500 Milibar Pressure Transmitter</b>	<ul style="list-style-type: none"> <li>■ FKM, EPDM, or NBR sealing materials for compatibility with a wide range of chemicals</li> <li>■ NPT, G (BSPP) process connections</li> <li>■ Multiple configurations ensure application compatibility</li> </ul>	19
	<b>PT1100 Mobile Equipment Pressure Transmitter</b>	<ul style="list-style-type: none"> <li>■ Ceramic measuring cells optimized for lower pressure range</li> <li>■ Meets international mobile equipment standards, including EMC resistance</li> <li>■ Gel filled stainless housing that minimizes failures from condensation</li> <li>■ Integral snubber to mitigate damage caused by pressure spikes</li> </ul>	21
	<b>PT2100 Mobile Equipment Pressure Transmitter</b>	<ul style="list-style-type: none"> <li>■ Stainless steel measuring cells</li> <li>■ Meets international mobile equipment standards, including EMC resistance</li> <li>■ Gel filled stainless housing that minimizes failures from condensation</li> <li>■ Integral snubber to mitigate damage caused by pressure spikes</li> </ul>	23
	<b>PT1 Series Pressure Transmitter</b>	<ul style="list-style-type: none"> <li>■ Stainless steel housing</li> <li>■ NPT and G (BSPP) process connections</li> <li>■ 4 - 20 mA, 0 - 10 V</li> <li>■ Ranges up to 600 Bar</li> </ul>	25

# PS+ Programmable Pressure Sensors

The PS+ series pressure sensor is a fully programmable pressure sensor that offers a local display as well as electrical outputs to provide critical feedback to a control system.



- Stainless steel measuring cell for pressure ranges >10bar
- Up to 600 bar relative pressure
- Accuracy up to 0.25%
- IO-Link 1.1
- Automatic signal detection
- Up to seven-fold overpressure resistance
- High protection class (IP6K6K, IP6K7, IP6K9K)
- 180° invertible multi-color display
- Rotatable sensor body



## Performance Data

Programmable Output Type 2UPN8	2X PNP/NPN N.O./N.C
Programmable Output Type LI2UPN8	**4 -20 mA, 0 - 20 mA, 0 - 10 V, 1 - 6 V, 0 - 5 V, 0.5 - 4.5 V and 1X PNP/NPN N.O./N.C or 2X PNP/NPN N.O./N.C.
Analog Accuracy (including LHR)	(1) +/- 0.5% Full Scale, (2) ± 0.25% full scale
Set Point Accuracy	(1) +/- 0.5% Full Scale, (2) ± 0.25% full scale
Set Point Range	(min + 0.005 x range) up to 100% of full scale
Reset Point Range	Min up to (SP - 0.005 x Range)
Set Point Hysteresis	≥ 0.5%
Temperature Coefficient Zero Point	(1) +/-0.15% of full scale/10K (2) +/-0.1% of full scale/10K
Temperature Coefficient Span	(1) +/-0.15% of full scale/10K (2) +/-0.1% of full scale/10K

## Electrical Data

Operating Voltage	18 - 30 VDC
Switching Current	≤ 250 mA
Voltage Drop	≤ 2 V
Switching Frequency	≤ 300 Hz
Response Time	≤ 500 ms
Short Circuit/Reverse Polarity Protection	Yes/Yes
IO-Link	Version 1.1

## Environmental Data

Ambient Temperature	-40 to 80 °C
Storage Temperature	-40 to 100 °C
Medium Temperature	-30 to 80 °C
Housing Materials	316L Stainless Steel/Polyarylamide 50%GF UL 94-V-0
Wetted Materials	(1) 316L Stainless Steel/AL2O3/FKM (2) 316L / 17-4 Stainless Steel
Protection Type	***IP6K6K/6K7/6K9K
LED Measuring Value	4 digit rotatable, red or green

(1) PS310

(2) PS510

\*\* Inverse analog outputs are programmable: example, 4-

\*\*\* Per ISO 20653 for electrical equipment mounted on roa than the typical IEC 60529; IP66, IP67, and IP69K



**Address:-** Sector 130, Shastri Garhi Shahpur, Noida, Uttar Pradesh- 201304

**Mob:-** +91 - 981187005, 9711966037, 9711966066

**Email:-** seereba@seereba.com, sales@seereba.com

**Website:-** www.seereba.com

# Part Number Key

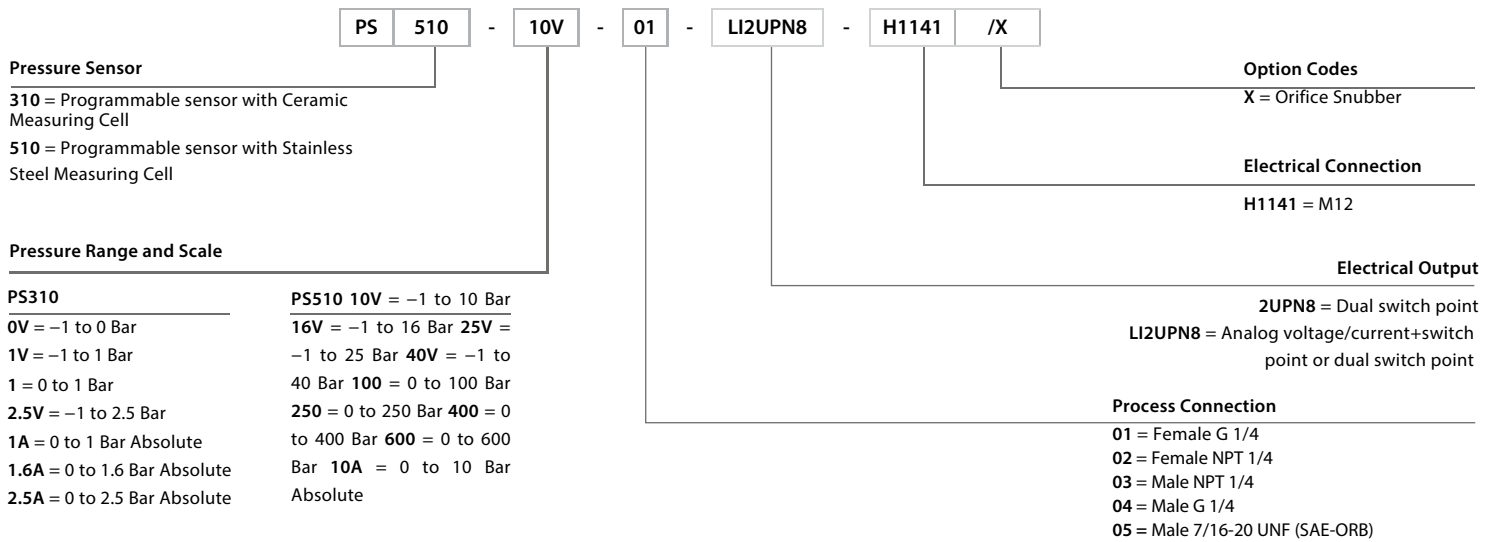

Consult factory for additional pressure ranges and process connections; note that above pressure ranges can be programmed and displayed in PSI, Kpa, Mpa, and additional user defined ranges

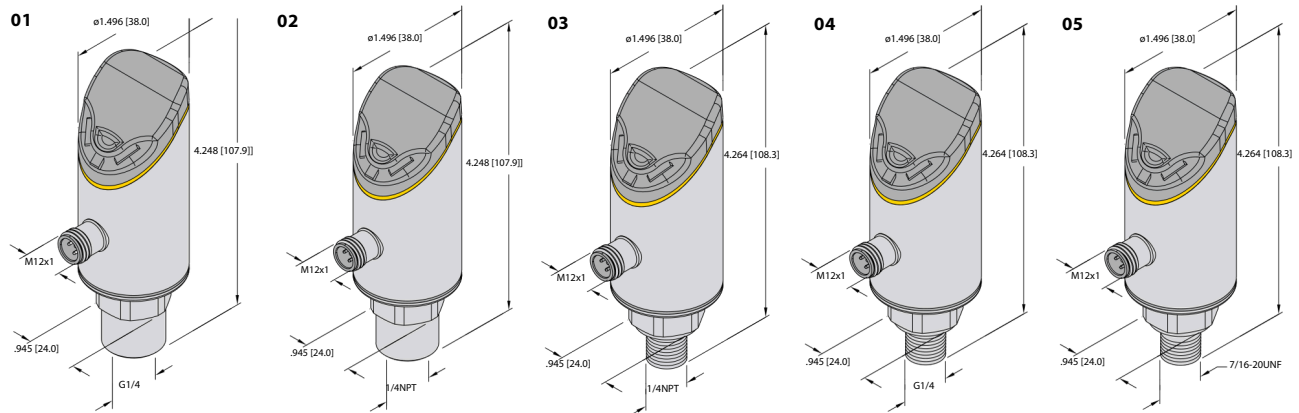
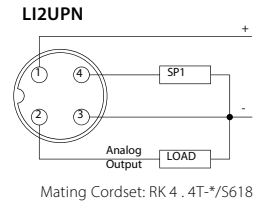
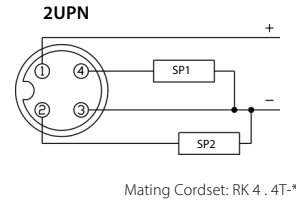

**Address:-** Sector 130, Shastri Garhi Shahpur, Noida, Uttar Pradesh- 201304  
**Mob:-** +91 - 981187005, 9711966037, 9711966066  
**Email:-** seereba@seereba.com, sales@seereba.com  
**Website:-** www.seereba.com

# PS Series Programmable Pressure Sensors

The PS series pressure sensor combines a fully programmable sensor with a digital display for local indication of pressure. Designed with a rugged stainless steel housing, these sensors will perform in the most demanding applications.

- Fully programmable output, functionality, scaling, and display
- Rugged 303 stainless steel housing
- NPT, G (BSPP), and SAE-ORB process connections
- Optional rotatable housing
- Ranges up to 600 Bar
- IO-Link



To be superseded by  
PS+ Programmable  
Pressure Sensor

## Performance Data

Over Pressure	See data sheet
Burst Pressure	See data sheet
Programmable Output Type 2UPN	2X PNP/NPN N.O./N.C 0 - 20 mA, 4 - 20 mA, 20 - 0 mA, 20 - 4 mA and 1X PNP/NPN N.O./N.C or 2X PNP/NPN N.O./N.C 0 - 10 V, 1 - 6 V, 0 - 5 V, 10 - 0 V, 6 - 1 V, 0 - 5 V and 1X PNP/NPN N.O./N.C or 2X PNP/NPN N.O./N.C $\pm 0.5\%$ full scale 0 - 75% measuring range $\pm 0.5\%$ full scale 1 - 100% measuring range 0.5 - 99.5% measuring range $\pm 0.5\%$ full scale $\leq 0.5\%$ measuring range $\leq 0.15\%$ of measuring range per 10 °C $\leq 0.15\%$ of measuring range per 10 °C
Programmable Output Type LI2UPN	
Programmable Output Type LUUPN	
Analog Accuracy LHR (LI2UPN8X and LUUPN)	
Programmable Analog Start Point (LI2UPN8X and LUUPN)	
Programmable Analog End Point (LI2UPN8X and LUUPN)	
Set Point Accuracy	
Set Point Range	
Reset Point Range	
Set Point Hysteresis	
Repeatability	
Temperature Coefficient Zero Point	
Temperature Coefficient Span	

## Electrical Data

Operating Voltage	18 - 30 VDC
Current Consumption	$\leq 50$ mA
Voltage Drop	$\leq 2$ V
Analog Load (LI2UPN8X and LUUPN8X)	$\leq 500 \Omega$
Switching Frequency	$\leq 180$ Hz
Response Time	$< 3$ ms
Short Circuit/Reverse Polarity Protection	Yes/Yes
IO-Link	Version 1.1

## Environmental Data

Ambient Temperature	-40 to 70 °C -40 to 80 °C -40 to 85 °C
Storage Temperature	303 stainless steel 303 stainless steel,
Medium Temperature	FPM, Al <sub>2</sub> O <sub>3</sub> ceramic IP 67/IP 69K 50 g per IEC 68-2-27 20 g (9 - 2000 Hz) per IEC 68-2-6 4 digit 7 segment display
Housing Materials	
Wetted Materials	
Protection Type	
Shock Resistance	
Vibration Resistance	
LED Measuring Value	



**Address:-** Sector 130, Shastri Garhi Shahpur, Noida, Uttar Pradesh- 201304

**Mob:-** +91 - 981187005, 9711966037, 9711966066

**Email:-** seereba@seereba.com, sales@seereba.com

**Website:-** www.seereba.com



**SEEREBa**

**Address:-** Sector 130, Shastri Garhi Shahpur, Noida, Uttar Pradesh- 201304

**Mob:-** +91 - 981187005, 9711966037, 9711966066

**Email:-** seereba@seereba.com, sales@seereba.com

**Website:-** www.seereba.com

## Part Number Key

<b>PS</b>	<b>010V</b>	-	<b>5</b>	<b>03</b>	-	<b>LI2UPN</b>	<b>8</b>	<b>X</b>	-	<b>H1141</b>
<b>Pressure Sensor</b>						<b>Electrical Connection</b>				
<b>Pressure Range and Scale</b>						<b>H1141 = 4-pin male, M12X1</b>				
<p>0.25V = -0.25 to 0.25 Bar (-3.63 to 3.63 PSIG)            01VR = -1 to 0 Bar (-14.5 to 0 PSIG)            001R = 0 to 1 Bar (0 to 14.5 PSIG)            001V = -1 to 1 Bar (-14.5 to 14.5 PSIG)            003V = -1 to 3 Bar (-14.5 to 43.5 PSIG)            010V = -1 to 10 Bar (-14.5 to 145 PSIG)            016V = -1 to 16 Bar (-14.5 to 232 PSIG)            025V = -1 to 25 Bar (-14.5 to 362.5 PSIG)            040V = -1 to 40 Bar (-14.5 to 580 PSIG)            100R = 0 to 100 Bar (0 to 1450 PSIG)            250R = 0 to 250 Bar (0 to 3625 PSIG)            400R = 0 to 400 Bar (0 to 5800 PSIG)            600R = 0 to 600 Bar (0 to 8700 PSIG)</p>						<b>With LED</b>				
<b>Housing</b>						<b>Operating Voltage</b>				
<p>3 = Non-Rotatable            5 = Rotatable</p>						<b>8 = 18 - 30 VDC</b>				
<b>Process Connection</b>						<b>Electrical Output</b>				
<p>01 = Female G 1/4            02 = Female NPT 1/4            03 = Male NPT 1/4            04 = Male G 1/4            05 = Male 7/16 - 20 UNF (SAE-ORB)</p>						<p>OUTPUT: <b>SP1</b>      <b>SP2/LOAD</b></p> <p><b>2UPN</b> = Switching output or IO-Link      Switching output  <b>LUUPN</b> = Switching output or IO-Link      Voltage output  <b>LI2UPN</b> = Switching output or IO-Link      Current/Switching output</p>				
						<p>Mating Cordset: RK 4 . 4T-*</p>		<p>Mating Cordset: RK 4 . 4T-*/S618</p>		<p>Mating Cordset: RK 4 . 4T-*/S618</p>

### Non-Rotatable

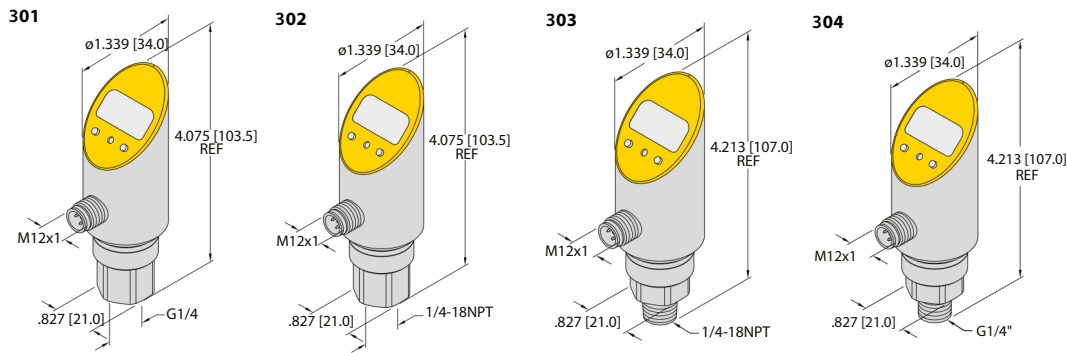

### Rotatable

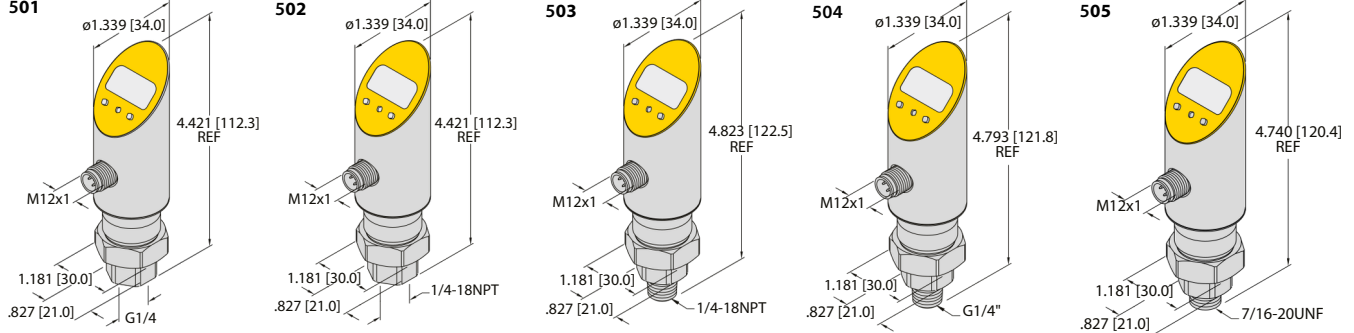

# PK Series Programmable Pressure Switches

The PK series pneumatic pressure switch combines a fully programmable sensor with a digital display for local indication of pressure. This sensor is ideal for general purpose pneumatic applications where cost and performance are required.



- Fully programmable output, display units and output functionality
- Pneumatic applications only
- Process connection NPT 1/8
- M8x1 Picofast electrical connection
- Two pressure ranges available: -1 to 0 Bar and 0 to 10 Bar

## Performance Data

Over Pressure	$\leq 5 \text{ Bar (01VR)} \leq 16 \text{ Bar (010R)}$
Burst Pressure	$\geq 5 \text{ Bar (01VR)} \geq 16 \text{ Bar (010R)}$
Programmable Output Type	2X PNP
Set Point Accuracy	$\leq \pm 1\% \text{ full scale}$
Switch Point	0 - 100% measuring range
Repeatability	0.02% full scale

## Electrical Data

Operating Voltage	10.8 - 30 VDC
Current Consumption	$< 35 \text{ mA}$
Switching Frequency	$\leq 400 \text{ Hz}$
Response Time	$< 2.5 \text{ ms}$

## Environmental Data

Ambient Temperature	$-20 \text{ to } 85 \text{ }^\circ\text{C}$ $-20 \text{ to } 85 \text{ }^\circ\text{C}$ $0 \text{ to } 50 \text{ }^\circ\text{C}$
Storage Temperature	Pico - ABS, Plastic; Nano - AL, PVC
Medium Temperature	Silicone, ABS, AL, Nickle plated brass
Housing Materials	IP 65 10 g XYZ 10 to 55 HZ, 1.5 mm, 3 planes 3-digit 7-segment display
Materials Exposed To Medium	
Protection Type	
Shock Resistance	
Vibration Resistance	
LED Measuring Value	



**Address:-** Sector 130, Shastri Garhi Shahpur, Noida, Uttar Pradesh- 201304

**Mob:-** +91 - 981187005, 9711966037, 9711966066

**Email:-** seereba@seereba.com, sales@seereba.com

**Website:-** www.seereba.com



**Address:-** Sector 130, Shastri Garhi Shahpur, Noida, Uttar Pradesh- 201304  
**Mob:-** +91 - 981187005, 9711966037, 9711966066  
**Email:-** seereba@seereba.com, sales@seereba.com  
**Website:-** www.seereba.com

## Part Number Key

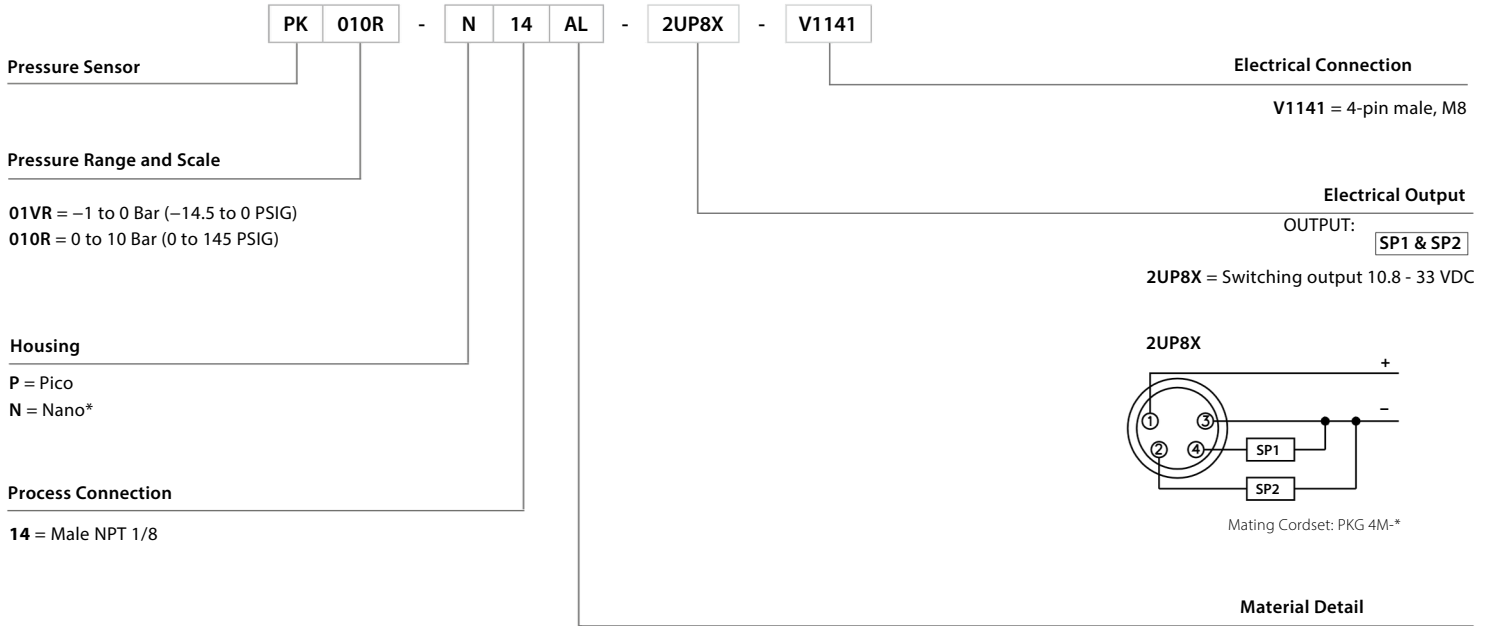

AL = Aluminum housing for Nano (N14)\* only

P 14

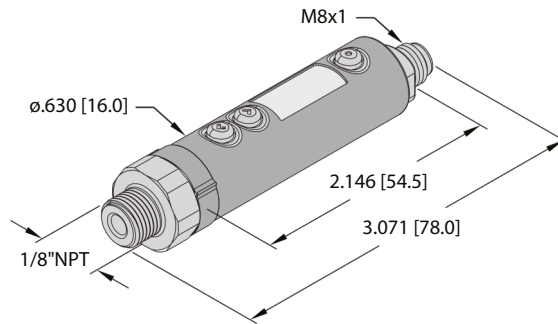

N 14 AL

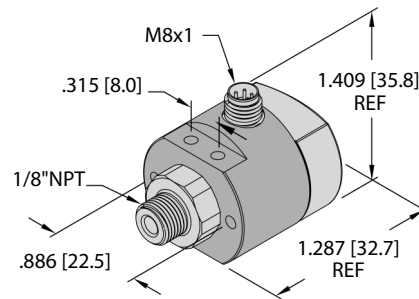

# PT1000/2000 Pressure Switch with IO-Link

The PT1000/2000 Pressure switch with IO-link is ideal for controlling pressure in industrial environments. Built on the platform of our rugged pressure transmitters, these switches feature two switching outputs independently adjustable via IO-Link. Additionally, IO-Link can be used to control the output state and switching behavior as well as providing diagnostic data to the control system. The housings are made from 316 stainless to ensure durability while the measuring cell is ceramic or stainless steel depending on the pressure range selected.



- Two independently configurable NO/NC, PNP/NPN switching outputs
- IO-Link communication for advanced diagnostics and sensor control
- Rugged design intended for demanding industrial applications

## Performance Data

Accuracy ± 0.3% full scale

## Electrical Data

Operating Voltage Output Type IOL	11 - 33 VDC
Outputs	IO-Link process data, 2x configurable switching outputs
Switching Current	100mA
Response Time	< 2 ms, typ. 1 ms
Short Circuit/Reverse Polarity Protection	Yes/Yes

## IO-Link Data

IO-Link Specification	V 1.1
Transmission Physics	Corresponds to 3-wire physics (PHY2)
Frame Type	2.2
Transmission Rate	COM 2/38.4 kbps
Programming	FDT/DTM
Diagnostics	Over/under pressure, short circuit, supply voltage, temperature, device fault, operating hours, high/low applied pressure

## Environmental Data

Ambient Temperature	-30 to 85 °C
Storage Temperature	-50 to 100 °C
Medium Temperature 1000 series	-40 to 125 °C
Medium Temperature 2000 series	-40 to 135 °C
Housing Materials	Stainless steel/plastic, 1.4404 (316L)/ polyarylamide 50% GF UL 94 V-0 316L
Process Connection Material	stainless steel Ceramic Al2O3, FPM 316L stainless steel IP67 / III
Wetted materials 1000 series	
Wetted materials 2000 series	
Protection Type	



**Address:-** Sector 130, Shastri Garhi Shahpur, Noida, Uttar Pradesh- 201304  
**Mob:-** +91 - 981187005, 9711966037, 9711966066  
**Email:-** seereba@seereba.com, sales@seereba.com  
**Website:-** www.seereba.com

# Part Number Key



**Functional Principle**  
Pressure Transmitter

**Pressure Range and Scale**

\*1VR = -1 to 0 Bar (-14.5 to 0 PSIG)  
 \*1R = 0 to 1 Bar (0 to 14.5 PSIG) \*4R = 0 to 4 Bar (0 to 58 PSIG) 10R = 0 to 10 Bar (0 to 145 PSIG) 25R = 0 to 25 Bar (0 to 362.5 PSIG) 40R = 0 to 40 Bar (0 to 580 PSIG) 60R = 0 to 60 Bar (0 to 870 PSIG) 100R = 0 to 100 Bar (0 to 1450 PSIG) 250R = 0 to 250 Bar (0 to 3625 PSIG) 400R = 0 to 400 Bar (0 to 5800 PSIG) 600R = 0 to 600 Bar (0 to 8700 PSIG)

**Design**

10 = Ceramic Measuring Cell  
 20 = Stainless Steel Measuring Cell

**Process Connection**

01 = Female G 1/4  
 03 = Male NPT 1/4  
 04 = Male G 1/4

**Option Codes**

/X = Pressure snubber

**Electrical Connection**

H1141 = M12x1

**Output Type**

IOL = 2x switching outputs, IO-Link programmable

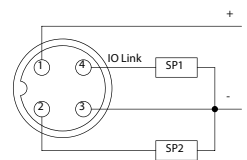

Recommended Mating Cordset: RK 4 - 4T-\*/S618

Consult factory for additional pressure ranges and process connections.  
 \* = Only available in a 1000 series with a ceramic measuring cell\*

01

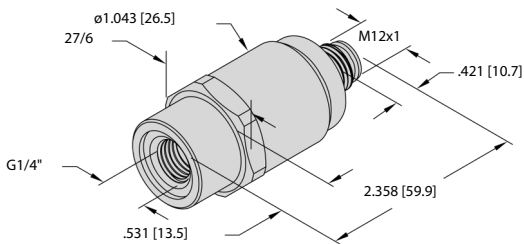

03

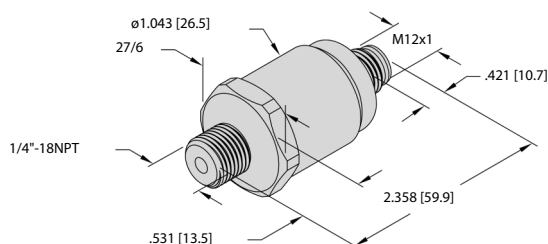

04

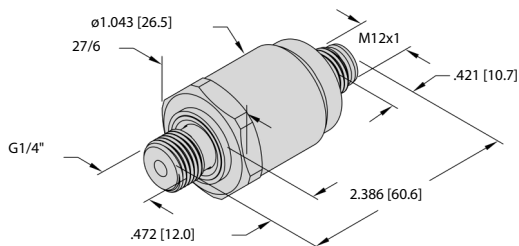

**Address:-** Sector 130, Shastri Garhi Shahpur, Noida, Uttar Pradesh- 201304

**Mob:-** +91 - 981187005, 9711966037, 9711966066

**Email:-** seereba@seereba.com, sales@seereba.com

**Website:-** www.seereba.com

# PT1000 Series Pressure Transmitters

The PT1000 series pressure transmitter offers excellent performance at an OEM price. The transmitter features a ceramic measuring cell that is well suited for general purpose pressure measurement applications. Features like a compact stainless steel housing, integral M12 connector, flexible process connections, and multiple pressure ranges ensure the product will fit the application.



Ceramic measuring elements 316 stainless steel housing with Polyarylamide 50% GF electrical connector NPT, G (BSPP), and SAE-ORB process connections Gel filled housing Ranges up to 60 bar

## Performance Data

Over Pressure	≤ 4 bar = 3X full scale > 4 bar = 2.5X full scale
Burst Pressure	≤ 4 bar = 3X full scale > 4 bar = 2.5X full scale
Analog Accuracy LHR	± 0.30% full scale
Temperature Coefficient Zero Point	± 0.20% of measuring range per 10 °C
Temperature Coefficient Span	± 0.20% of measuring range per 10 °C

## Electrical Data

Operating Voltage (I2 & U3)	7 - 33 VDC
Operating Voltage (U1)	12 - 33 VDC
Operating Voltage (U2)	8 - 33 VDC
Operating Voltage (U6)	5 VDC regulated
Current Consumption (I2)	≤ 23 mA
Current Consumption (U1, U2, U3, U6)	≤ 7 mA
Analog Load (I2)	≤ supply voltage - 7 V/0.02 A = Ω
Analog Load (U1, U2, U3, U6)	> 10 K Ω
Response Time	< 2 ms
Short Circuit/Reverse Polarity Protection	Yes/Yes

## Environmental Data

Ambient Temperature	-30 to 85 °C -50 to 100 °C -40 to 125 °C 316 stainless steel/Polyarylamide 50% GF 316 stainless steel, FPM, AL <sub>2</sub> O <sub>3</sub>
Storage Temperature	ceramic IP 67 40 g for 6 ms, 1000x all 3 directions per IEC 68-2-
Medium Temperature	29 20 g, 15 - 2000 Hz, 15 - 25 Hz with amplitude μ 15 mm,
Housing Materials	1 Octave/min. all 3 directions, 50 constant load per IEC 68-2-6
Wetted Materials	
Protection Type	
Shock Resistance	
Vibration Resistance	



**Address:-** Sector 130, Shastri Garhi Shahpur, Noida, Uttar Pradesh- 201304

**Mob:-** +91 - 981187005, 9711966037, 9711966066

**Email:-** seereba@seereba.com, sales@seereba.com

**Website:-** www.seereba.com



**SEEREBa**

**Address:-** Sector 130, Shastri Garhi Shahpur, Noida, Uttar Pradesh- 201304

**Mob:-** +91 - 981187005, 9711966037, 9711966066

**Email:-** seereba@seereba.com, sales@seereba.com

**Website:-** www.seereba.com

## Part Number Key

PT 10R - 10 01 - I2 - H1141

Pressure Transmitter

Pressure Range and Scale

Absolute Range

- 1A = 0 to 1 BarA (0 to 14.5 PSIA)
- 2A = 0 to 1.6 BarA (0 to 23.2 PSIA)
- 3A = 0 to 2.5 BarA (0 to 36.25 PSIA)
- 4A = 0 to 4 BarA (0 to 58 PSIA)
- 6A = 0 to 6 BarA (0 to 87 PSIA)
- 10A = 0 to 10 BarA (0 to 145 PSIA)

Compound Range

- 0.2V = -0.2 to 0.2 Bar (-2.9 to 2.9 PSIG)
- 1V = -1 to 1 Bar (-14.5 to 14.5 PSIG)
- 1.5V = -1 to 1.5 Bar (-14.5 to 21.75 PSIG)
- 2.5V = -1 to 2.5 Bar (-14.5 to 36.25 PSIG)
- 5V = -1 to 5 Bar (-14.5 to 72.5 PSIG)
- 9V = -1 to 9 Bar (-14.5 to 130.5 PSIG)
- 15V = -1 to 15 Bar (-14.5 to 217.5 PSIG)
- 24V = -1 to 24 Bar (-14.5 to 348 PSIG)
- 40V = -1 to 40 Bar (-14.5 to 580 PSIG)
- 15PSIV = -15 to 15 PSIG
- 45PSIV = -15 to 45 PSIG
- 85PSIV = -15 to 85 PSIG
- 130PSIV = -15 to 130 PSIG
- 185PSIV = -15 to 185 PSIG
- 285PSIV = -15 to 285 PSIG
- 485PSIV = -15 to 485 PSIG

Series

10 = Ceramic measuring cell

Process Connection 01 = Female G

Relative Ranges

- 1VR = -1 to 0 Bar (-14.5 to 0 PSIG)
- 0.25R = 0 to 0.25 Bar (0 to 3.63 PSIG)
- 1R = 0 to 1 Bar (0 to 14.5 PSIG)
- 2R = 0 to 1.6 Bar (0 to 23.2 PSIG)
- 3R = 0 to 2.5 Bar (0 to 36.35 PSIG)
- 4R = 0 to 4 Bar (0 to 58 PSIG)
- 6R = 0 to 6 Bar (0 to 87 PSIG)
- 10R = 0 to 10 Bar (0 to 145 PSIG)
- 16R = 0 to 16 Bar (0 to 232 PSIG)
- 25R = 0 to 25 Bar (0 to 362.5 PSIG)
- 40R = 0 to 40 Bar (0 to 580 PSIG)
- 60R = 0 to 60 Bar (0 to 870 PSIG)
- 15PSIG = 0 to 15 PSIG
- 20PSIG = 0 to 20 PSIG
- 30PSIG = 0 to 30 PSIG
- 60PSIG = 0 to 60 PSIG
- 100PSIG = 0 to 100 PSIG
- 150PSIG = 0 to 150 PSIG

- 200PSIG = 0 to 200 PSIG
- 300PSIG = 0 to 300 PSIG
- 500PSIG = 0 to 500 PSIG
- 750PSIG = 0 to 750 PSIG

\*other ranges available upon request

PT...1001

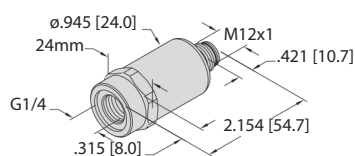

PT...1003

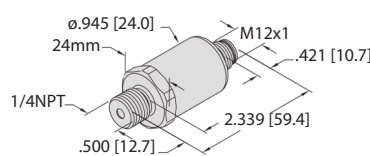

PT...1004

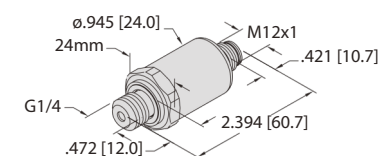

PT...1005

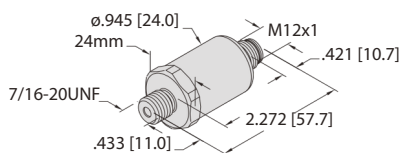

PT...1014

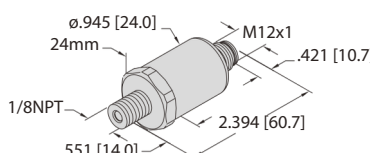

PT...1017

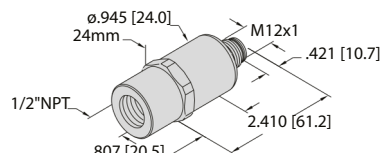

Electrical Connection

Current Output 2-wire

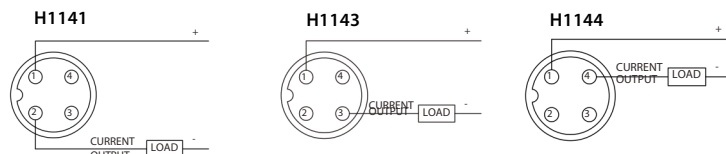

Voltage Output 3-wire

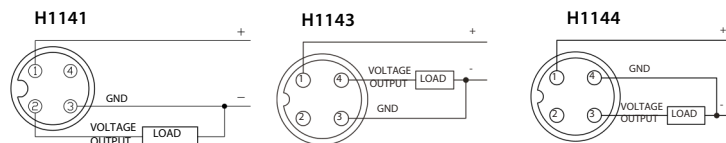

Mating Cordset: RK 4.4T\* / 5618

Electrical Output

- I2 = 4 - 20 mA (2-wire)
- U1 = 0 - 10 VDC (3-wire)
- U2 = 1 - 6 VDC (3-wire)
- U3 = 0 - 5 VDC (3-wire)
- U6 = 0.5 - 4.5% (3-wire) [ratiometric]

# PT2000 Series Pressure Transmitters

The PT2000 series pressure transmitter offers excellent performance at an OEM price. The transmitter features a stainless steel measuring cell that is well suited for liquid measurement applications. The stainless measuring cell and gel filled housing inhibit liquid ingress while protecting the sensor from internal condensation common in liquid pumping applications.

- 316 welded stainless steel measuring element
- 316 stainless steel housing with Polyarylamide
- 50% GF electrical connector
- NPT, G (BSPP), and SAE-ORB process connections
- Gel filled housing
- Ranges up to 1000 Bar



## Performance Data

Over Pressure	≤ 6 bar = 5X full scale (max 1500 Bar) > 6 bar = 3X full scale (max 1500 Bar)
Burst Pressure	≤ 6 bar = 10X full scale (max 2500 Bar) > 6 bar = 6X full scale (max 2500 Bar)
Analog Accuracy LHR	± 0.30% full scale
Temperature Coefficient Zero Point	± 0.20% of measuring range per 10 °C
Temperature Coefficient Span	± 0.20% of measuring range per 10 °C

## Electrical Data

Operating Voltage (I2 & U3)	7 - 33 VDC
Operating Voltage (IX)	10-30 VDC
Operating Voltage (U1)	12 - 33 VDC
Operating Voltage (U2)	8 - 33 VDC
Operating Voltage (U6)	5 VDC regulated
Current Consumption (I2)	≤ 23 mA
Current Consumption (U1, U2, U3, U6)	≤ 7 mA
Analog Load (I2)	≤ supply voltage - 7 V/0.02 A = Ω
Analog Load (U1, U2, U3, U6)	> 10 K Ω
Response Time	< 2 ms
Short Circuit/Reverse Polarity Protection	Yes / Yes
ATEX Approval (IX)	II 1/2 GD Ex ia IIC T4 Ga/Gb Ex ia IIIC T125 °C Da/Db

## Environmental Data

Ambient Temperature	-30 to 85 °C -50 to 100 °C -40 to 135 °C 316 stainless
Storage Temperature	steel/Polyarylamide 50% GF 316 stainless steel (≤ 60 bar 430 stainless
Medium Temperature	steel) IP 67 40 g for 6 ms, 1000x all 3 directions per IEC 68-2-29 20 g,
Housing Materials	15 - 2000 Hz, 15 - 25 Hz with amplitude μ 15 mm,1 Octave/min.
Wetted Materials	all 3 directions, 50 constant load per IEC 68-2-6
Protection Type	
Shock Resistance	
Vibration Resistance	



**Address:-** Sector 130, Shastri Garhi Shahpur, Noida, Uttar Pradesh- 201304

**Mob:-** +91 - 981187005, 9711966037, 9711966066

**Email:-** seereba@seereba.com, sales@seereba.com

**Website:-** www.seereba.com



**SEEREBa**

**Address:-** Sector 130, Shastri Garhi Shahpur, Noida, Uttar Pradesh- 201304

**Mob:-** +91 - 981187005, 9711966037, 9711966066

**Email:-** seereba@seereba.com, sales@seereba.com

**Website:-** www.seereba.com

## Part Number Key

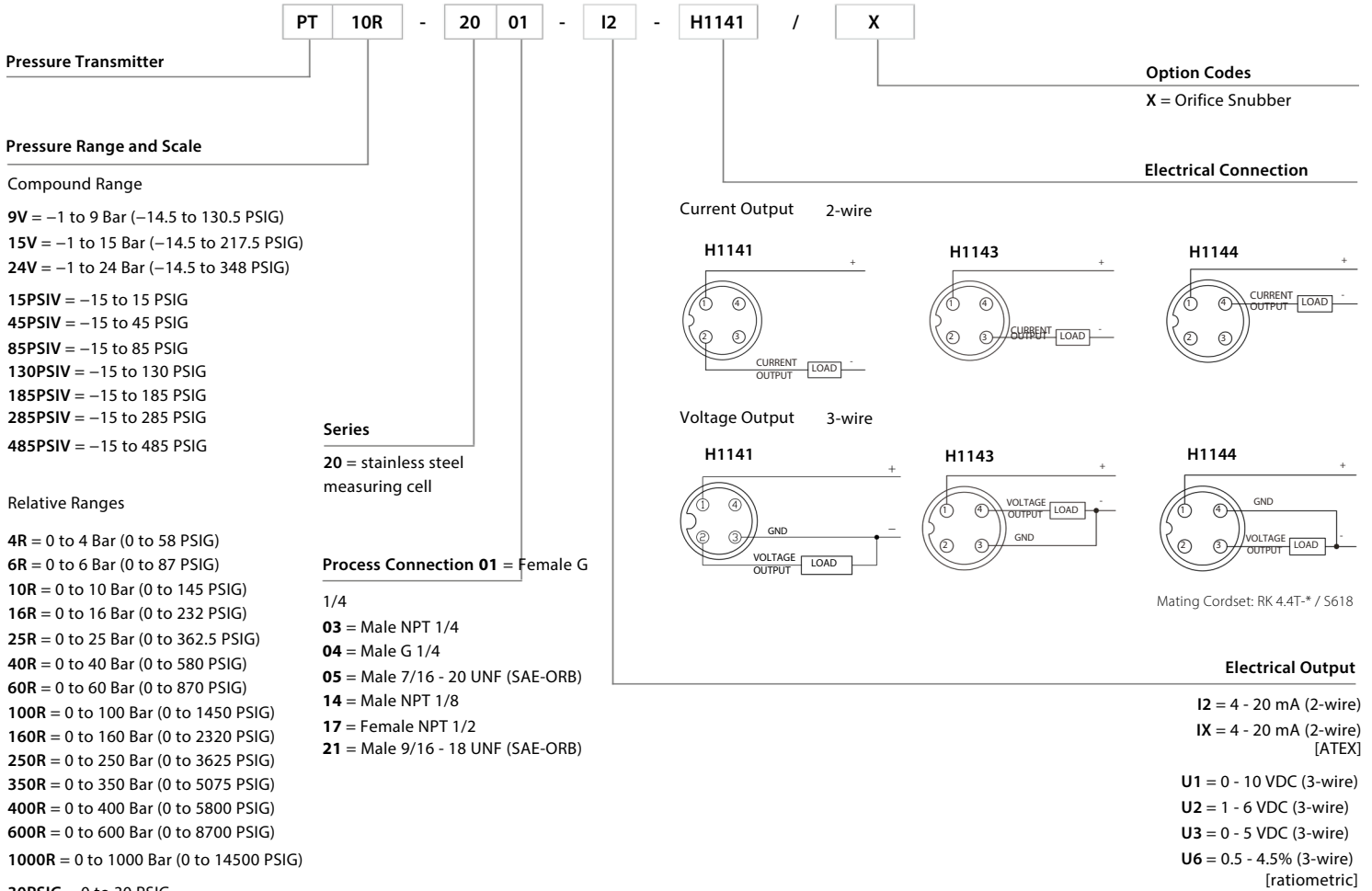

PT...2001

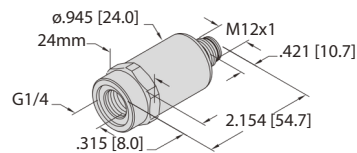

PT...2003

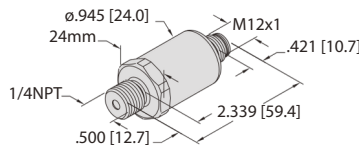

PT...2004

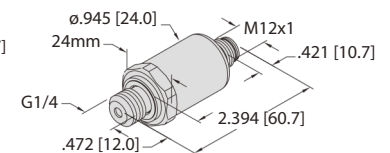

PT...2005

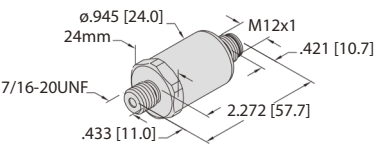

PT...2014

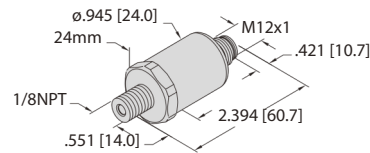

PT...2017

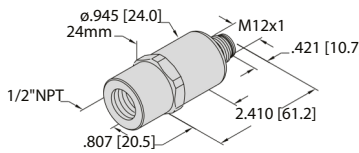

PT...2021

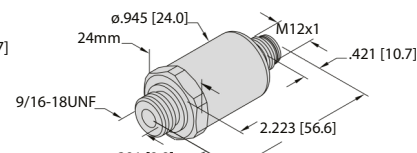

# PT1500 Pressure Transmitter

The PT1500 series pressure transmitter is optimized for measuring low pressure. With ranges as low as 50 mbar this transmitter is well suited for liquid level applications. A housing made from 316L stainless steel and a ceramic measuring cell ensures the product will survive in demanding industrial applications.



## Features

- PM, EPDM, or NBR sealing materials for compatibility with a wide range of chemicals
- NPT and G (BSPP) process connections
- Multiple configurations ensure application compatibility

### Performance Data

Admissible Over Pressure	≤ 2 bar
Burst Pressure	≥ 2 bar
Analog Accuracy	± 0.35% or ± 0.7% Full scale, variant dependant
Temperature Coefficient Span	± 0.07% FS/10 K
Vertical position error, pressure connection at top	+ 0.2 mbar
Horizontal position error	+ 0.1 mbar

### Electrical Data

Operating Voltage Output Type, I2	7 - 33 VDC
Operating Voltage Output Type, U1	12 - 33 VDC
Operating Voltage Output Type, U3	7 - 33 VDC
Current Consumption Output Type, I2	≤ 23 mA
Current Consumption Output Type, U1, U3	≤ 5 mA
Analog Load Output Type, I2 Analog Load	≤ (Supply voltage-10)/20 kΩ
Output Type, U1, U3 Response Time Short	≥ 10 kΩ
Circuit/Reverse Polarity Protection	< 150 ms
	Yes/ Yes

### Environmental Data

Ambient Temperature	Storage Temperature	Medium Temperature	
-25 to 85 °C	-40 to 85 °C	-25 to 85 °C	Stainless steel/Plastic, 1.4404 (316L)/ Polyarylamide 50%
Housing Materials	Process Connection		Stainless steel 1.4404 (AISI 316L) IP67 / III EPDM NBR FPM
Material Protection Type	Sealing Material - /D830 variant	Sealing Material - /D831 variant	Sealing Material - /D840 (standard)
Measuring Cell Material			

Ethylene propylene  
Butadiene acrylonitrile  
Fluoro elastomer  
Ceramic, Al<sub>2</sub>O<sub>3</sub>



**Address:-** Sector 130, Shastri Garhi Shahpur, Noida, Uttar Pradesh- 201304

**Mob:-** +91 - 981187005, 9711966037, 9711966066

**Email:-** seereba@seereba.com, sales@seereba.com

**Website:-** www.seereba.com

## Part Number Key

PT 1PSIG - 15 03 - 12 - H1143 /D840

### Functional Principle

Pressure Transmitter

### Pressure Range

0.1VR = -0.10 to 0 bar	1PSIV = -1 to 1 psi
0.05V = -0.05 to 0.05 bar	2PSIV = -2 to 2 psi
0.1V = -0.10 to 0.10 bar	3PSIV = 3 to 3 psi
0.16V = -0.16 to 0.16 bar	5PSIV = -5 to 5 psi
0.2V = -0.20 to 0.20 bar	1PSIG = 0 to 1 psi
0.3V = -0.30 to 0.3 bar	2PSIG = 0 to 2 psi
0.05R = 0 to 0.05 bar	3PSIG = 0 to 3 psi
0.1R = 0 to 0.1 bar	5PSIG = 0 to 5 psi
0.16R = 0 to 0.16 bar	10PSIG = 0 to 10 psi
0.2R = 0 to 0.2 bar	
0.25R = 0 to 0.25 bar	
0.3R = 0 to 0.3 bar	
0.4R = 0 to 0.4 bar	
0.6R = 0 to 0.6 bar	

### Design

PT1500 Low Pressure

Consult factory for additional pressure ranges and process connections.

### Seal

D830 = EPDM seal  
 D831 = NBR seal  
 D840 = FPM seal

### Electrical Connection

#### Current Output 2-wire

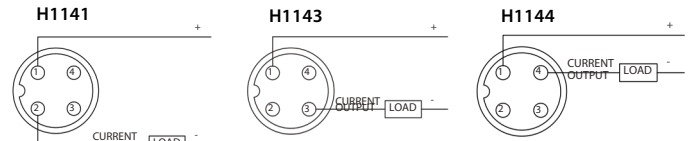

#### Voltage Output 3-wire

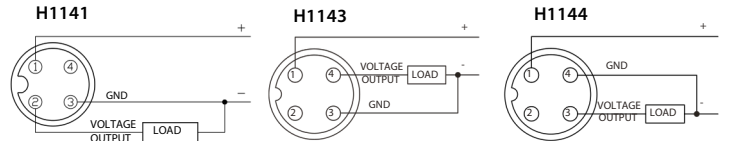

Mating Cordset: RK 4.4T-\* / S618

### Output Type

U1 = 0 to 10 V (3-wire)  
 U3 = 0 to 5 V (3-wire)  
 I2 = 4 to 20 mA (2-wire)  
 U6 = Ratiometric (10 to 90%) (3-wire)

### Process Connection

01 = Female G 1/4  
 03 = Male NPT 1/4-18  
 04 = Male G 1/4  
 13 = Male G 1/8

01

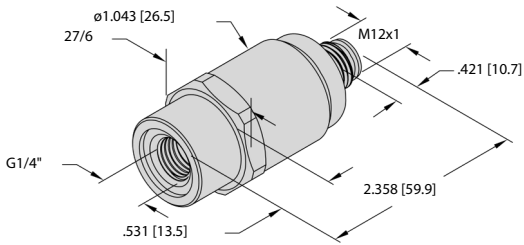

03

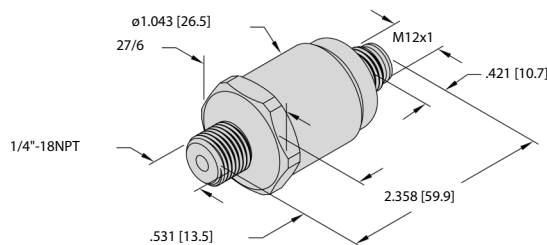

04

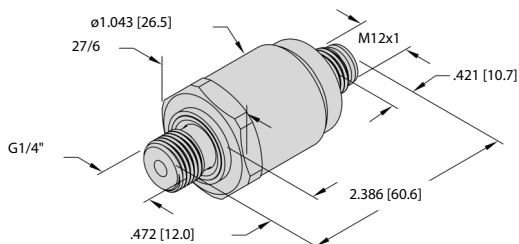

13

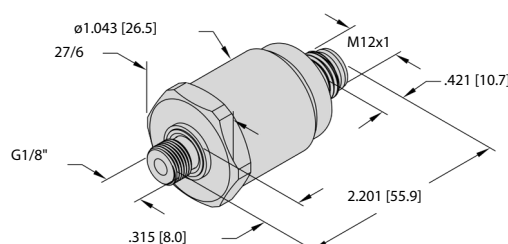

# PT1100 Series Pressure Transmitters

The PT1100 series pressure transmitters are designed from the ground up for the challenges encountered in mobile equipment. Features such as ceramic measuring cells, integral Deutsch connectors, multiple pressure ranges, process connections, and robust electrical circuits ensure long service life.

- Ceramic measuring cell optimized for lower pressure range
- Meets international mobile equipment standards, including EMC resistance
- Gel filled stainless steel housing that minimizes failures from condensation
- Integral snubber to mitigate damage caused by pressure spikes
- Pressure ranges and process connections common on mobile hydraulic systems



## Performance Data

Over Pressure	See datasheet	See datasheet ± 0.3%
Burst Pressure	See datasheet	full scale ± 0.2% of measuring range
Analog accuracy LHR		per 10°K
Thermal characteristics		

## Electric Data

Operating voltage (I2)	Operating voltage (U3)	Operating voltage (U6)	7.5 - 33 VDC
Current consumption (I2)	Current consumption (U3, U6)	Analog Load (I2)	5 VDC (regulated)
Analog Load (U3, U6)	Response time	Short Circuit/reverse polarity protection	≤ 23 mA
Environmental Data	Ambient temperature	Storage temperature	≤ 7 mA
Housing materials	Medium temperature		≤ (Supply voltage - 7.5) / 20KΩ
			≤ 100 nF / >10 kΩ
			< 2ms, typ. 1 ms
			Yes/Yes

Wetted Materials	-40° - 100°C -50° - 100°C -40° - 125°C	Stainless steel (1.4404)
Protection type		/ AISI 316 L Polyarylamide 50% Gf UL 94 V-0
Vibration resistance		Stainless steel (1.4404) / AISI 316 L, FPM, AL <sub>2</sub> O <sub>3</sub> ceramic
Shock resistance		IP69K / III
		Test VI (12 g, sinusoidal 18 g random vibration)
		50 g, 11 ms, half sine wave, 1000x/axis , acc. to ISO 16750-3

EMC	EN 61326-2-3 - Pressure transducer	<b>Immunity Motor Vehicle Directive</b>	ISO 11452-2, HF (Field), 100 V/m (200...2000 MHz)
<b>Interference Immunity/</b>	ISO 13766 - Earthmoving machinery		ISO 11452-4, HF (BCI), 100 mA (20...400 MHz)
<b>Interference Emission:</b>	DIN EN 13309 - Construction machinery		ISO 10605, ESD, ±15 kV contact, ±15 kV air
	DIN ISO 14982 - Forestry and agriculture		ISO 7637-2 3), pulses 1, 2a, 2b, 3a, 3b (test level 4)
	CISPR11		ISO 16750-2, load dump, 155 V (1 Ω, 300 ms)



**Address:-** Sector 130, Shastri Garhi Shahpur, Noida, Uttar Pradesh- 201304

**Mob:-** +91 - 981187005, 9711966037, 9711966066

**Email:-** seereba@seereba.com, sales@seereba.com

**Website:-** www.seereba.com



**Address:-** Sector 130, Shastri Garhi Shahpur, Noida, Uttar Pradesh- 201304  
**Mob:-** +91 - 981187005, 9711966037, 9711966066  
**Email:-** seereba@seereba.com, sales@seereba.com  
**Website:-** www.seereba.com

## Part Number Key

PT 100PSIG - 11 05 - I2 - DT043P

### Pressure Transmitter

### Pressure Range and Scale

- 1VR = -1 to 0 Bar (-14.5 to 0 PSIG)
- 1V = -1 to -1 Bar (-14.5 to 14.5 PSIG)
- 1R = 0 to 1 Bar (0 to 14.5 PSIG)
- 10R = 0 to 10 Bar (-14.5 to 0 PSIG)
- 15PSIG = 0 to 15 PSIG
- 100PSIG = 0 to 100 PSIG

### Series

### Process Connection 05 = Male

- 7/16 - 20 UNF (SAE-ORB)
- 21 = Male 9/16 - 18 UNF (SAE-ORB)
- 04 = Male G1/4
- 03 = Male 1/4 NPT

### Electrical Connection

DT04-3P= DT04 Duetsch Connector

I2

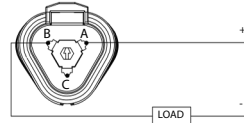

U3 & U6

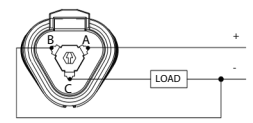

Mating Cordset: DT06-3S-1876-\*

### Electrical Output

- I2 = 4 - 20 mA (2-wire)
- U3 = 0 - 5 VDC (3-wire)
- U6 = Ratiometric (3 wire) 0.5 to 4.5 VDC

\*Contact factory for additional pressure ranges, process connections, and electrical connections

PT...1105

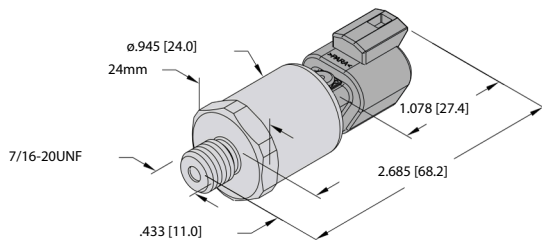

PT...1121

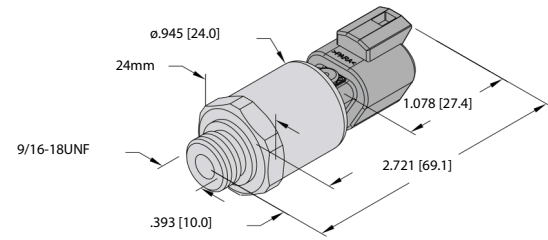

PT...1104

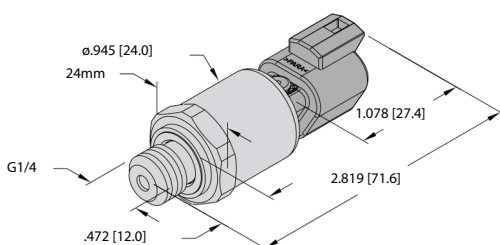

PT...1103

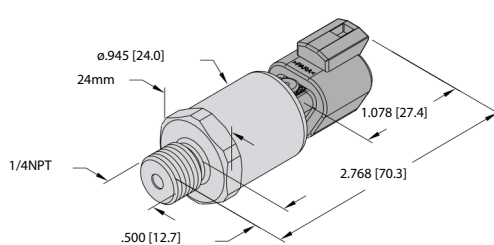

# PT2100 Series Pressure Transmitters

The PT2100 series pressure transmitters are designed from the ground up for the challenges encountered in mobile equipment. Features such as stainless measuring cells, integral Deutsch connectors, multiple pressure ranges, process connections, and robust electrical circuits ensure long service life

- Stainless steel measuring cell
- Meets international mobile equipment standards, including EMC resistance
- Gel filled stainless steel housing that minimizes failures from condensation
- Integral snubber to mitigate damage caused by pressure spikes
- Pressure ranges and process connections common on mobile hydraulic systems



## Performance Data

Over Pressure	See datasheet	See datasheet ± 0.3%
Burst Pressure		full scale ± 0.2% of measuring range
Analog Accuracy LHR		per 10°K
Thermal characteristics		

## Electric Data

Operating voltage (I2)	Operating voltage (U3)	Operating voltage (U6)	7.5 - 33 VDC
Current consumption (I2)	Current consumption (U3, U6)	Analog Load (I2)	5 VDC (regulated)
Analog Load (U3, U6)	Response time	Short Circuit/reverse polarity protection	≤ 23 mA
Environmental Data	Ambient temperature	Storage temperature	≤ 7 mA
Medium temperature	Medium temperature	Housing materials	≤ (Supply voltage - 7.5) / 20KΩ
			≤ 100 nF / > 10 kΩ
			< 2ms, typ. 1 ms
			Yes/Yes

Wetted Materials	-40° - 100°C	-50° - 100°C	-40° - 125°C	Stainless steel (1.4404)
Protection type	/ AISI 316 L Polyarylamide 50% Gf UL 94 V-0 Stainless steel			
Vibration resistance	(1.4404) / AISI 316 L IP69K / III Test VI (12 g, sinusoidal 18 g random vibration) 50 g, 11 ms, half sine wave, 1000x/axis , acc. to ISO 16750-3			
Shock resistance				

## EMC

**Interference Immunity/  
Interference Emission**

EN 61326-2-3 - Pressure transducer  
ISO 13766 - Earthmoving machinery  
DIN EN 13309 - Construction machinery  
DIN ISO 14982 - Forestry and agriculture  
CISPR11

## Immunity Motor Vehicle Directive

ISO 11452-2, HF (Field), 100 V/m (200...2000 MHz)  
ISO 11452-4, HF (BCI), 100 mA (20...400 MHz)  
ISO 10605, ESD, ±15 kV contact, ±15 kV air  
ISO 7637-2 3), pulses 1, 2a, 2b, 3a, 3b (test level 4)  
ISO 16750-2, load dump, 155 V (1 Ω, 300 ms)  
Motor vehicle directive ECE R10



**Address:-** Sector 130, Shastri Garhi Shahpur, Noida, Uttar Pradesh- 201304

**Mob:-** +91 - 981187005, 9711966037, 9711966066

**Email:-** seereba@seereba.com, sales@seereba.com

**Website:-** www.seereba.com



**SEEREBa**

**Address:-** Sector 130, Shastri Garhi Shahpur, Noida, Uttar Pradesh- 201304

**Mob:-** +91 - 981187005, 9711966037, 9711966066

**Email:-** seereba@seereba.com, sales@seereba.com

**Website:-** www.seereba.com

## Part Number Key

PT 3000PSIG - 21 05 - I2 - DT043P

### Pressure Transmitter

### Pressure Range and Scale

- 500PSIG = 0 to 500 PSIG
- 750PSIG = 0 to 750 PSIG
- 1000PSIG = 0 to 1000 PSIG
- 2000PSIG = 0 to 2000 PSIG
- 3000PSIG = 0 to 3000 PSIG
- 3500PSIG = 0 to 3500 PSIG
- 5000PSIG = 0 to 5000 PSIG
- 6000PSIG = 0 to 6000 PSIG
- 7500PSIG = 0 to 7500 PSIG
- 40R = 0 to 40 Bar (0 to 580 PSIG)
- 60R = 0 to 60 Bar (0 to 870 PSIG)
- 100R = 0 to 100 Bar (0 to 1450 PSIG)
- 160R = 0 to 160 Bar (0 to 2230 PSIG)
- 250R = 0 to 250 Bar (0 to 3625 PSIG)
- 400R = 0 to 400 Bar (0 to 5800 PSIG)
- 600R = 0 to 600 Bar (0 to 7500 PSIG)

### Series

21 = Mobile Equipment Pressure Transmitter

### Process Connection

- 05 = Male 7/16"-20 UNF (SAE-ORB)
- 21 = Male 9/16"-18 UNF (SAE-ORB)
- 04 = Male G1/4
- 03 = Male 1/4" NPT

### Electrical Connection

DT04-3P= DT04 Duetsch Connector

I2

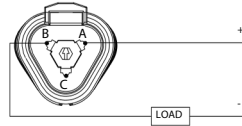

U3 & U6

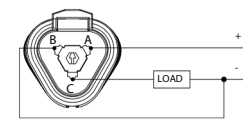

Mating Cordset: DT06-3S-1876-\*

### Electrical Output

- I2 = 4-20 mA (2 wire)
- U3 = 0-5 VDC (3 wire)
- U6 = Ratiometric (3 wire) 0.5 to 4.5 VDC

\*Contact factory for additional pressure ranges, process connections, and electrical connections

PT...2105

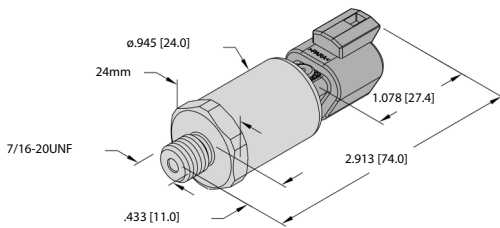

PT...2121

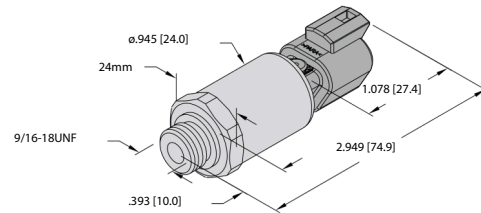

PT...2104

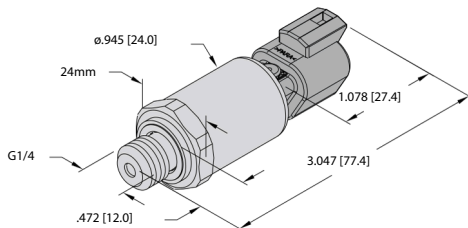

PT...2103

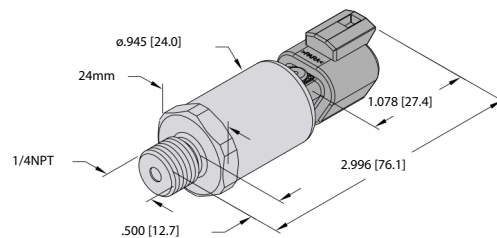

# PT1 Series Pressure Transmitters

The PT1 pressure transmitter is a general purpose product with a ceramic measuring cell and is ideal for pneumatic applications. The rugged stainless steel housing ensures performance in demanding applications.

- Stainless steel housing
- NPT and G (BSPP) process connections
- I - 20 mA, 0 - 10 V
- Ranges up to 600 Bar

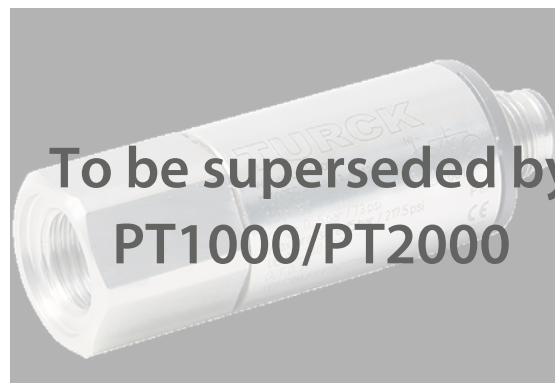

## Performance Data

Over Pressure	$\leq 4 \text{ bar} = 3X \text{ full scale}$ $> 4 \text{ bar} = 2.5X \text{ full scale}$
Burst Pressure	$\leq 4 \text{ bar} = 3X \text{ full scale}$ $> 4 \text{ bar} = 2.5X \text{ full scale}$
Analog Accuracy LHR	$\leq 0.30\% \text{ full scale}$
Zero/Span Shift	$\leq 0.30\% \text{ full scale}$
Temperature Coefficient Zero Point	$\leq 0.15\% \text{ of measuring range per } 10^\circ\text{C}$
Temperature Coefficient Span	$\leq 0.15\% \text{ of measuring range per } 10^\circ\text{C}$

## Electrical Data

Operating Voltage (LI3)	8 - 33 VDC
Operating Voltage (LU2)	11.4 - 33 VDC
Current Consumption	$\leq 20 \text{ mA}$
Analog Load (LI3)	$\leq 1 \text{ K } \Omega$
Analog Load (LU2)	$> 10 \text{ K } \Omega$
Response Time	$< 2 \text{ ms}$
Short Circuit/Reverse Polarity Protection	Yes/Yes

## Environmental Data

Ambient Temperature	-40 to 85 °C
Storage Temperature	-40 to 85 °C
Medium Temperature	-40 to 125 °C
Housing Materials	303 stainless steel
Wetted Materials	303 stainless steel, FPM, PPS, AL <sub>2</sub> O <sub>3</sub> ceramic
Protection Type	IP 67
Shock Resistance	75 g, 11 ms per IEC 68-2-27
Vibration Resistance	20 g, 15 mm per IEC 68-2-6



**Address:-** Sector 130, Shastri Garhi Shahpur, Noida, Uttar Pradesh- 201304

**Mob:-** +91 - 981187005, 9711966037, 9711966066

**Email:-** seereba@seereba.com, sales@seereba.com

**Website:-** www.seereba.com

## Part Number Key

PT 010R - 1 1 - LI3 - H1131

### Pressure Transmitter

### Pressure Range and Scale

#### Absolute Range

- 001A = 0 to 1 BarA (0 to 14.5 PSIA)
- 002A = 0 to 1.6 BarA (0 to 23.2 PSIA)
- 003A = 0 to 3 BarA (0 to 43.5 PSIA)

#### Relative Ranges

- 01VR = -1 to 0 Bar (-14.5 to 0 PSIG)
- 0.5R = 0 to 0.5 Bar (0 to 7.25 PSIG)
- 001R = 0 to 1 Bar (0 to 14.5 PSIG)
- 002R = 0 to 1.6 Bar (0 to 23.2 PSIG)
- 003R = 0 to 2.5 Bar (0 to 36.25 PSIG)
- 004R = 0 to 4 Bar (0 to 58 PSIG)
- 006R = 0 to 6 Bar (0 to 87 PSIG)
- 010R = 0 to 10 Bar (0 to 145 PSIG)
- 016R = 0 to 16 Bar (0 to 232 PSIG)
- 025R = 0 to 25 Bar (0 to 362.5 PSIG)
- 040R = 0 to 40 Bar (0 to 580 PSIG)
- 060R = 0 to 60 Bar (0 to 870 PSIG)
- 100R = 0 to 100 Bar (0 to 1450 PSIG)
- 160R = 0 to 160 Bar (0 to 2320 PSIG)
- 250R = 0 to 250 Bar (0 to 3625 PSIG)
- 400R = 0 to 400 Bar (0 to 5800 PSIG)
- 600R = 0 to 600 Bar (0 to 8700 PSIG)

-30HG = -30 to 0 in HG

15PSIG = 0 to 15 PSIG

30PSIG = 0 to 30 PSIG

60PSIG = 0 to 60 PSIG

100PSIG = 0 to 100 PSIG

200PSIG = 0 to 200 PSIG

300PSIG = 0 to 300 PSIG

500PSIG = 0 to 500 PSIG

750PSIG = 0 to 750 PSIG

1000PSIG = 0 to 1000 PSIG

2000PSIG = 0 to 2000 PSIG

3000PSIG = 0 to 3000 PSIG

5000PSIG = 0 to 5000 PSIG

7500PSIG = 0 to 7500 PSIG

### Series

1 = PT1

### Process Connection

1 = Female G 1/4

3 = Male NPT 1/4

### Electrical Connection

H1131 = 3-pin, M12

### Electrical Output

OUTPUT:

LOAD

LI3 = 4 - 20 mA

LU2 = 0 - 10 VDC

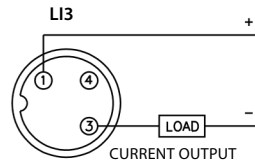

Mating Cordset: RK 4T-\* / S618

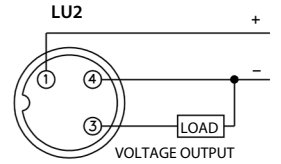

Mating Cordset: RK 4T-\* / S618

PT...11

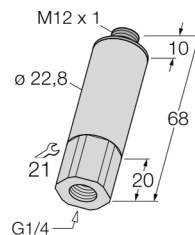

PT...13

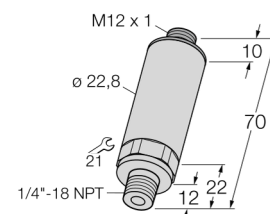

# Accessories

## ProcessConnectionAdaptors

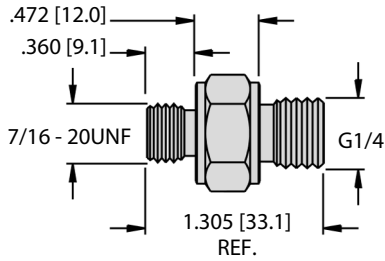

PCV-S7/16A4 | A9136

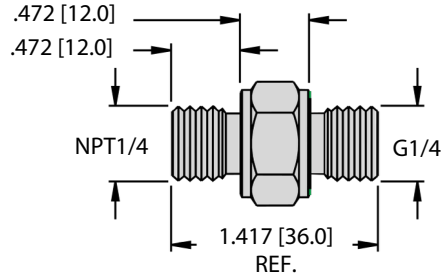

PCV-N1/4A4 | A9867

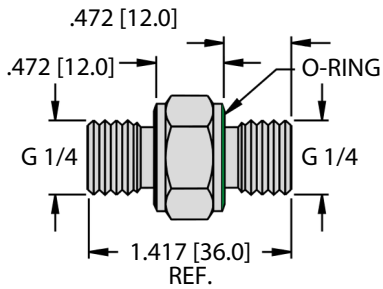

PCV-G1/4A4 | M6835011

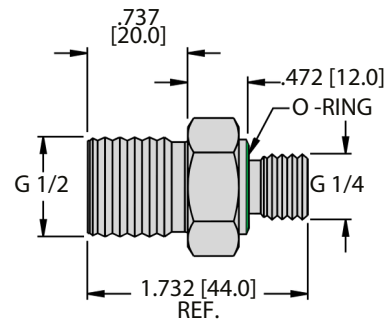

PCV-G1/2A4 | M6835012

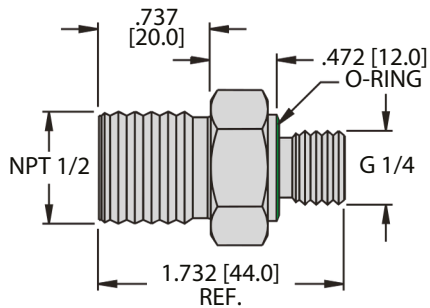

PCV-N1/2A4 | M6835013

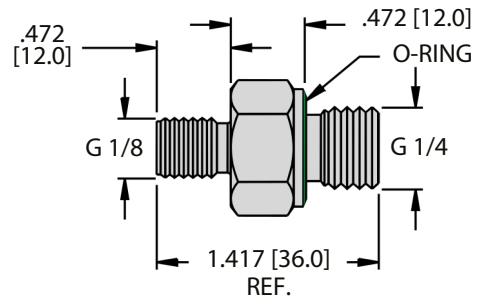

PCV-G1/8A4 | M6835014

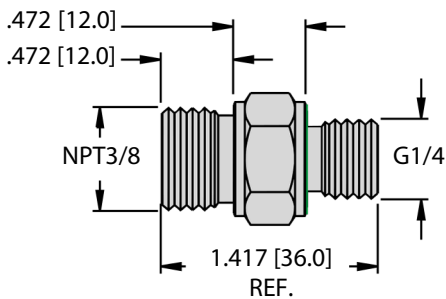

PCV-N3/8A4 | M6835020

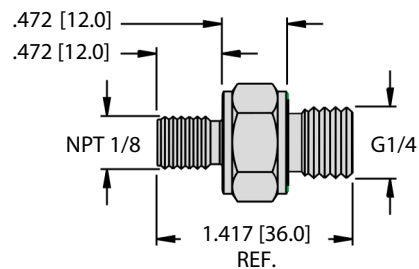

PCV-N1/8A4 | M6835021

**Protective Adaptors**

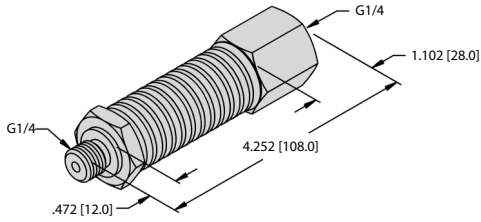

**Heat Exchanger**

PCS-G1/4A4 | M6835015

*\*\*view High Temperature Applications on page 30*

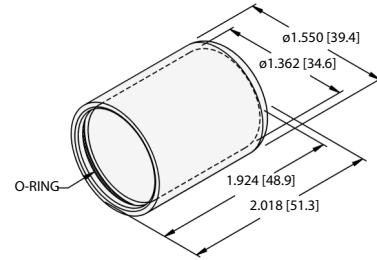

**PS Series Cover**

PTS-COVER | A9350

*NOTE: only works with PS series sensors*

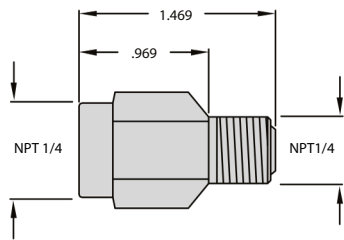

**Pressure Snubber**

PSC-N1/4A4-OIL | 100000742

PSC-N1/4A4-WATER | 100000741

*\*view Pressure Spike And Transients on page 29*

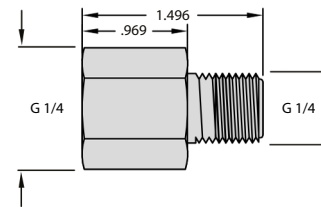

**Pressure Snubber**

PSC-G1/4A4-OIL | 100000744

PSC-G1/4A4-WATER | 100000740

*\*view Pressure Spike And Transients on page 29*

**Mounting Adaptors**

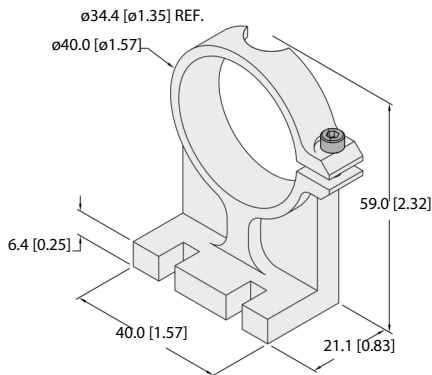

**Mounting Brackets**

PS/TS-MBT | A9919

*NOTE: only works with PS series sensors*

Mounting bracket for PS+ Programmable Pressure Sensor

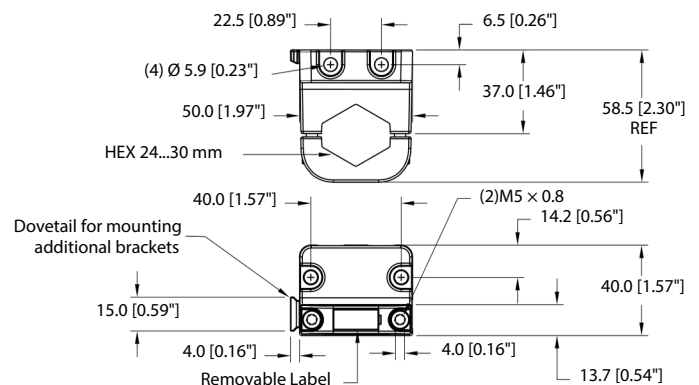

# Diaphragm Seal Selection

A diaphragm seal works as an isolator between the pressure sensor and the process media. They are commonly used for corrosive applications where compatibility is an issue, sanitary applications where a 3A or food grade rating is required, and where a clean out is required due to media that may build up on the sensor face over time. Diaphragms can be made of many different materials; typically the upper housing is made of the same or similar material as the sensor, because it does not come in contact with the process media. The diaphragm and lower housing can come in different materials. This ensures compatibility of process media that is not compatible with the sensor. For example, salt water will corrode stainless steel over time but will not affect Hastelloy.

## Assembly Part Numbers

Diaphragm S numbers are added to the end of the sensor part number. In order to place an order with a diaphragm:

1. You will first want to pick the correct sensor for your application (ex: PS010V-303-LI2UPN8X-H1141).
2. Then pick the diaphragm with the housing materials needed (ex: PS010V-303-LI2UPN8X-H1141/S1604).  
*\*NOTE: more information about /S1604 diaphragm on page 23*
3. Contact applications for chemical compatibility and other optional materials not listed to prolong the life of the sensor.

① **UPPER**

The upper housing does not come in contact with the process media.

② **LOWER**

The lower housing and diaphragm should be the same material, as they are both in contact with the process media.

③ **FLUID FILL**

This is a non-compressible fluid. In general applications, Silicone DC200 is used. For sanitary applications, Neobe M20 is generally used.

④ **O-RING**

O-rings seal the upper and lower housings to the diaphragm.

⑤ **DIAPHRAGM**

The diaphragm is the barrier between the process media and the fluid fill/sensor.

⑥ **PROCESS CONNECTION**

This is where the process media (1/4 or 1/2 NPT) enters the assembly.

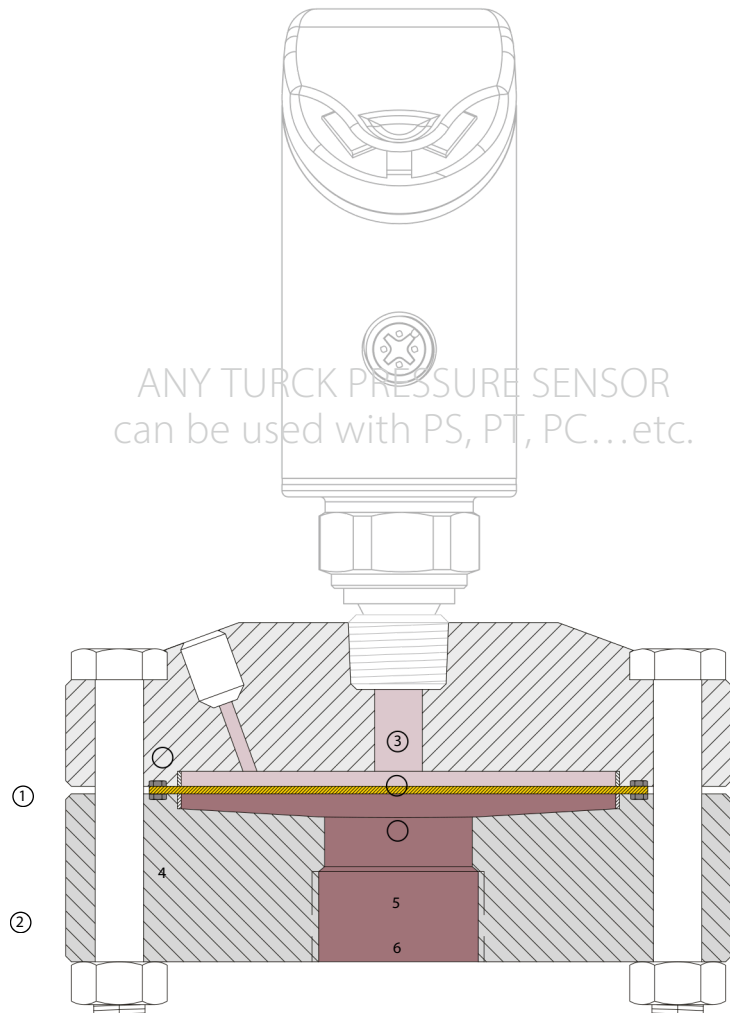

**Address:-** Sector 130, Shastri Garhi Shahpur, Noida, Uttar Pradesh- 201304

**Mob:-** +91 - 981187005, 9711966037, 9711966066

**Email:-** seereba@seereba.com, sales@seereba.com

**Website:-** www.seereba.com



**Fully Welded Diaphragms With Clean Out**  
 In applications with medias present that can either build up over time or may clog the sensor, fully welded diaphragm seals with clean-out may be added to any of Turck's pressure sensors.

The clean out port allows for quick and easy cleaning of the diaphragm and lower housing.

ANY TURCK PRESSURE SENSOR

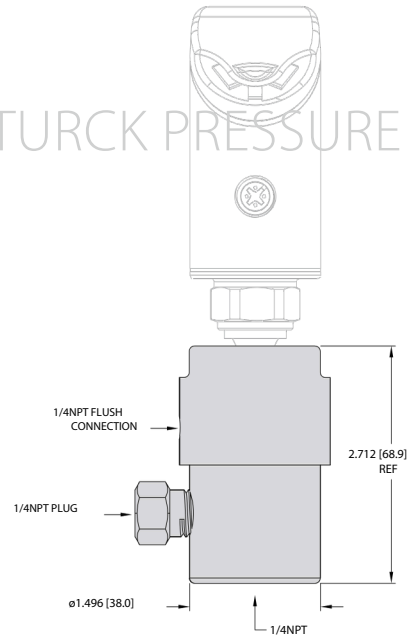

**Fully Welded Diaphragm Seal With Clean Out**

Part Numbers

Upper Housing Material

Lower Housing Material

Fluid Fill Material

Diaphragm Material

Process Connection

Maximum Working Pressure (at 100 °F)

S1593  
 316L  
 316L  
 silicone DC200  
 316L  
**1/4" Female NPT**  
 2500 PSI

**Flush Mount Diaphragms**

In applications with medias present that can either build up over time or may clog the sensor, flush mount diaphragm seals may be added to any of Turck's pressure sensors.

The diaphragm is located on the bottom of the process connection, eliminating any orifices to clog.

ANY TURCK PRESSURE SENSOR

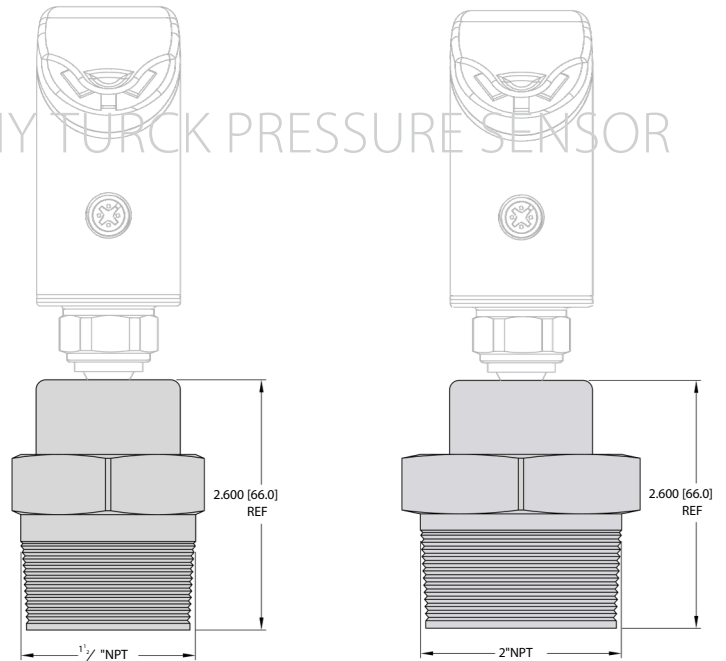

**Flush Mount Diaphragm Seal**

Part Numbers Upper Housing

Material Lower Housing Material

Fluid Fill Material Diaphragm

Material Process Connection

Maximum Working Pressure (at 100 °F)

S1704  
 316L  
 316L  
 silicone DC200  
 316L  
**1.5" Male NPT**  
 3500 PSI

S1705  
 316L  
 316L  
 silicone DC200  
 316L  
**2" Male NPT**  
 2500 PSI

## Sanitary Diaphragms

In applications with sanitary medias, a sanitary diaphragm seal can be added to any of Turck's pressure sensors.

The diaphragm is made of food grade Stainless steel with a micro finish that meets or exceeds the 3A requirements.

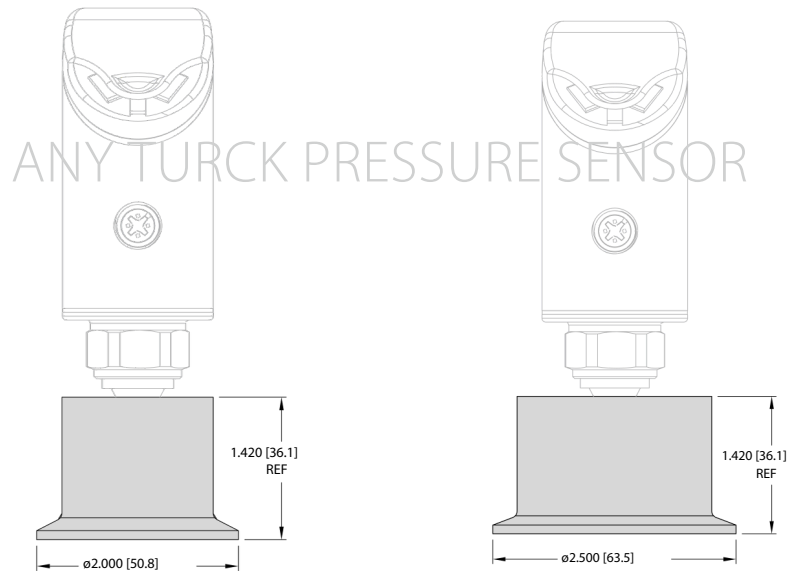

### Sanitary Diaphragm Seal

Part Numbers Upper Housing  
 Material Lower Housing Material  
 Fluid Fill Material Diaphragm  
 Material Process Connection  
 Maximum Working Pressure (at 100 °F)

S1604  
 316L  
 316L  
 Neobe M20  
 316L  
 1.5" Triclamp  
 600 PSI

S1605  
 316L  
 316L  
 Neobe M20  
 316L  
 2" Triclamp  
 600 PSI



**Address:-** Sector 130, Shastri Garhi Shahpur, Noida, Uttar Pradesh- 201304  
**Mob:-** +91 - 981187005, 9711966037, 9711966066  
**Email:-** seereba@seereba.com, sales@seereba.com  
**Website:-** www.seereba.com

# Application Considerations

## Sizing Pressure Sensors

When sizing a pressure sensor, you typically want to over size for the application. This will allow for any over pressures that may occur. For instance, if you are running an application that is always at 100 PSI in a dynamic application, you will want to spec in a transmitter that is 50% larger (or the next size up that is reasonable). Keeping the process pressure within that range will help with any pressure spike failures that are caused by system start up or other system processes. In the case of level static applications, oversizing the pressure sensor approximately 10% is all that is needed, providing best resolution for your application.

## Pressure Sensor Measurement Types

There are different types of pressure measurement. Below are a few that Turck has to offer. To help further the explanation of the measurement types, see Sensor References (pg. 25) for a deeper look into the terminology.

**Absolute** sensors will have a pressure zero reference to absolute pressure.

**Gauge** sensors will have a pressure zero reference to atmosphere.

**Sealed** sensors will have a sealed zero reference that is not open to atmosphere or to absolute vacuum.

**Compound** sensors have a gauge zero reference, but are able to go from a vacuum to a positive pressure, the zero point of the sensor is atmospheric pressure.

**Differential** sensors use two measurement cells; one for high pressure and one for low pressure. The differential pressure is Cell 1 - Cell 2.

## Pressure Units

There are many types of pressure units, all of which can be converted by a constant. Outlined below are the common units and how to convert between them (Fig. 2).

## Pressure Units Conversion Chart

UNIT	bar	mbar	Pa	kPa	mPa	mmHg	PSI	1" WC
bar	1	1000	100000	100	0.1	0.0013	14.5038	0.0025
mbar	1000	1	100	0.1	0.0001	1.3332	0.0145	2.4884
Pa	100000	100	1	0.001	1.00E-06	133.3224	0.000145	248.84
kPa	100	0.1	0.001	1	0.001	0.1333	0.145	0.2488
mPa	0.1	0.0001	1.00E-06	0.001	1	0.0001	145.0377	0.0002
mmHg	750.0617	0.75	0.0075	7.5006	0.0001	1	0.01934	0.5352
PSI	14.5038	0.0145	0.0001	0.145	145.0377	0.01934	1	0.0361
1" WC	401.865	0.4019	0.00402	0.2488	0.0002	0.5352	0.0361	1

### Sensor References

All pressure sensors have a reference point, and there are different types of reference points available. The reference point helps keep the zero point of the transmitter at a constant value. Depending on the application, it may be necessary to use different types of pressure references for the device. To the right are the three most common types.

Pressure sensors get their reference via a hole on the side, top, or bottom of the sensor, which is usually sealed by a hydrophobic material. Alternatively, pressure sensors can get their reference via a vent tube. This is the only way a submersible sensor can get its reference, unless sealed or absolute. This is achieved by having a tube that runs through the electrical cable to allow a vent between atmosphere and the back side of the measuring cell (Fig. 3).

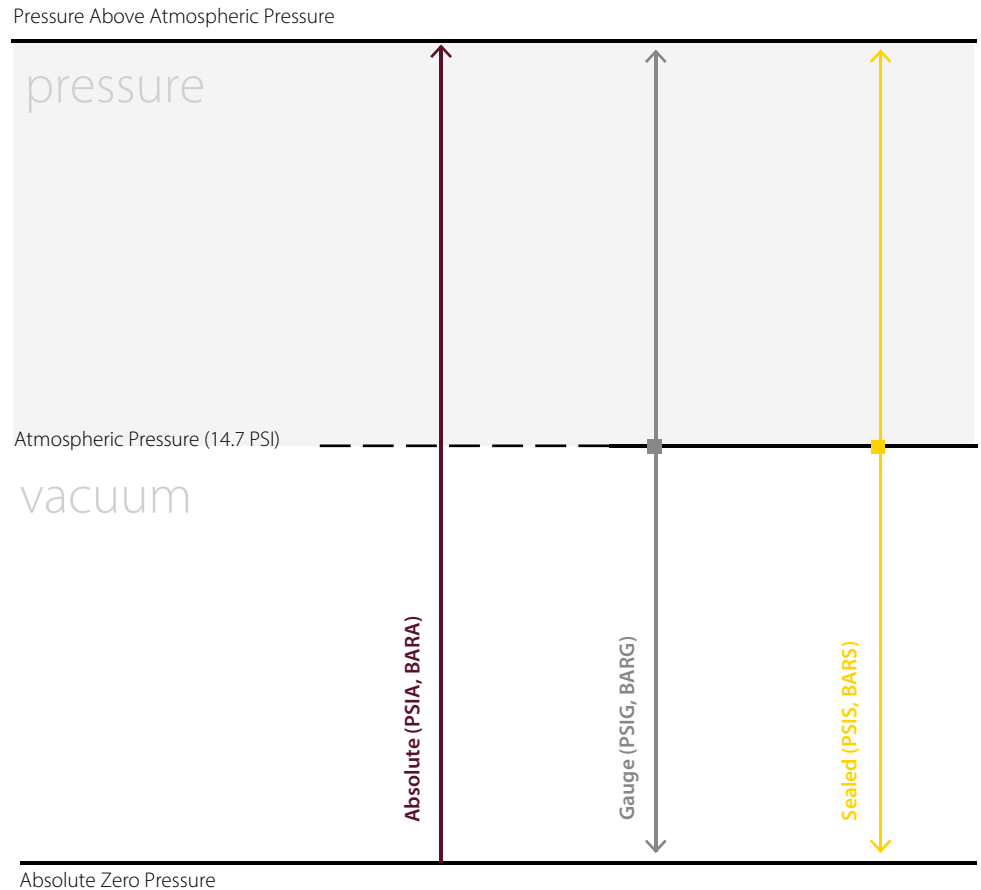

Fig. 3

- **Absolute (PSIA, BARA)** reference is when the back side of the pressure sensor's measuring cell is placed under a vacuum and is sealed. This shifts the sensors zero point to a value of  $-1$  bar. This reference is commonly used to detect changes in barometric pressure.
- ↔ **Gauge (PSIG, BARG)** reference is when the back side of the pressure sensor is open to atmospheric pressure. This is the most common type of reference on a pressure sensor, as it allows for the zero point to move with atmospheric conditions.
- ↔ **Sealed (PSIS, BARS)** reference is when the back side of the pressure sensor is sealed when manufactured. This may induce a small error when used in different elevation from where it was manufactured. This is commonly used to increase the sensors IP rating or to help alleviate water intrusion.

**Atmospheric Pressure** is the amount of pressure produced by the weight of the atmosphere. This can change relative to elevation from sea level as well as shifts in barometric pressure.

## Sensor Accuracy

Accuracy is the maximum deviation from the theoretical linear line between a sensor's zero and span output seen by the characteristic curve observed in testing under specified conditions and by a specified procedure. Accuracy must include Linearity, Hysteresis, and Repeatability (LHR).

**Non-Linearity** is where inconsistency comes in. Two methods are typically used: **Best Fit Straight Line (BFSL)**, and **Full Scale (FS)** or Terminal Point.

**Hysteresis** is the maximum difference in sensor output at a pressure when that pressure is first approached with pressure increasing, and then approached with pressure decreasing during a full span pressure cycle.

**Non-Repeatability** is the maximum difference in output when the same pressure is applied, consecutively, under the same conditions and approaching from the same direction.

If accuracy is an important characteristic in specifying the pressure transmitter, it may be important to calculate the total error band of the sensor.

**The total error band** accounts for accuracy, sensor stability, thermal effect on zero/span, and zero/span shift. This will take into account all of the potential errors that may be induced on the sensor. Total error band is calculated with the below formula:

$$\text{Total error band} = \sqrt{[(\text{accuracy}^2) + (\text{stability}^2) + (\text{TE zero}^2) + (\text{TE span}^2) + (\text{zero shift}^2) + (\text{span shift}^2)]}$$

## Temperature Effects On Accuracy

Temperature behavior on a pressure sensor can be represented in two ways. The first way would be to give a temperature compensated range on the device; this is the range where the sensor's testing was done and the accuracy LHR % holds true. Outside of the temperature compensated range, there may be an increased accuracy deviation. This is usually shown on the data sheet as the temperature compensated zero/span value.

The second way this is represented would be to give the sensor an accuracy deviation per a given temperature deviation (i.e., the PT2000 series). The zero and span shift represent an error that can be induced from operating the sensor outside of reference condition. The reference condition for temperature on this series is 15 to 25 °C. For example, if you were operating the sensor between 26 °C and 35 °C, it could shift the linear line an added  $\pm 0.15\%$ .

In regards to accuracy deviations, please keep in mind that these are not simply added together. For instance, since the device has an accuracy of 0.3%—and an added 0.15% in the example above due to operating at 10 °C above the reference condition—the total is not 0.45%. To properly calculate accuracy deviations, add the root of the sums squared using the formula below:

$$\sqrt{[(0.3)^2 + (0.15)^2]}$$

$$\sqrt{[0.09 + 0.0225]} = \pm 0.34\%$$

In the example below, the device is operating at a maximum temperature range of 125 °C, which is 100 °C above the reference condition. The total error induced by the increased temperature would be calculated as follows:

$$\sqrt{[(0.3)^2 + (0.15)^2 + (0.15)^2 + (0.15)^2 + (0.15)^2 + (0.15)^2 + (0.15)^2 + (0.15)^2 + (0.15)^2 + (0.15)^2 + (0.15)^2 + (0.15)^2]} = \pm 0.56\%$$

Generally, when a shift occurs it will move the zero and span in the same direction.



**Address:-** Sector 130, Shastri Garhi Shahpur, Noida, Uttar Pradesh- 201304

**Mob:-** +91 - 981187005, 9711966037, 9711966066

**Email:-** seereba@seereba.com, sales@seereba.com

**Website:-** www.seereba.com



**Address:-** Sector 130, Shastri Garhi Shahpur, Noida, Uttar Pradesh- 201304  
**Mob:-** +91 - 981187005, 9711966037, 9711966066  
**Email:-** seereba@seereba.com, sales@seereba.com  
**Website:-** www.seereba.com

Accuracy typically is called out as an LRH%, which is calculated using the below formula:

$$\text{Accuracy | LRH\%} = \sqrt{[(\text{non-linearity}^2) + (\text{non-repeatability}^2) + (\text{hysteresis}^2)]}$$

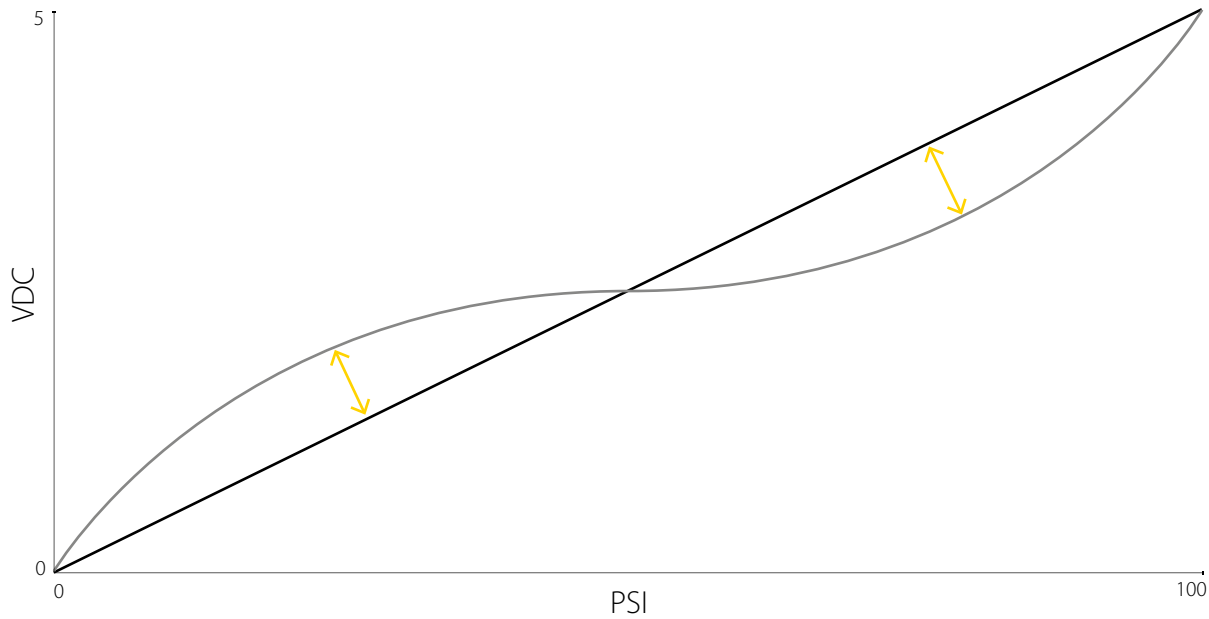

**Full scale accuracy (FS)** is the relationship of plotted characteristics of the pressure cell and the calculated straight line that starts and stops at the cells endpoints. The greatest deviation from the linear line would be the accuracy deviation.

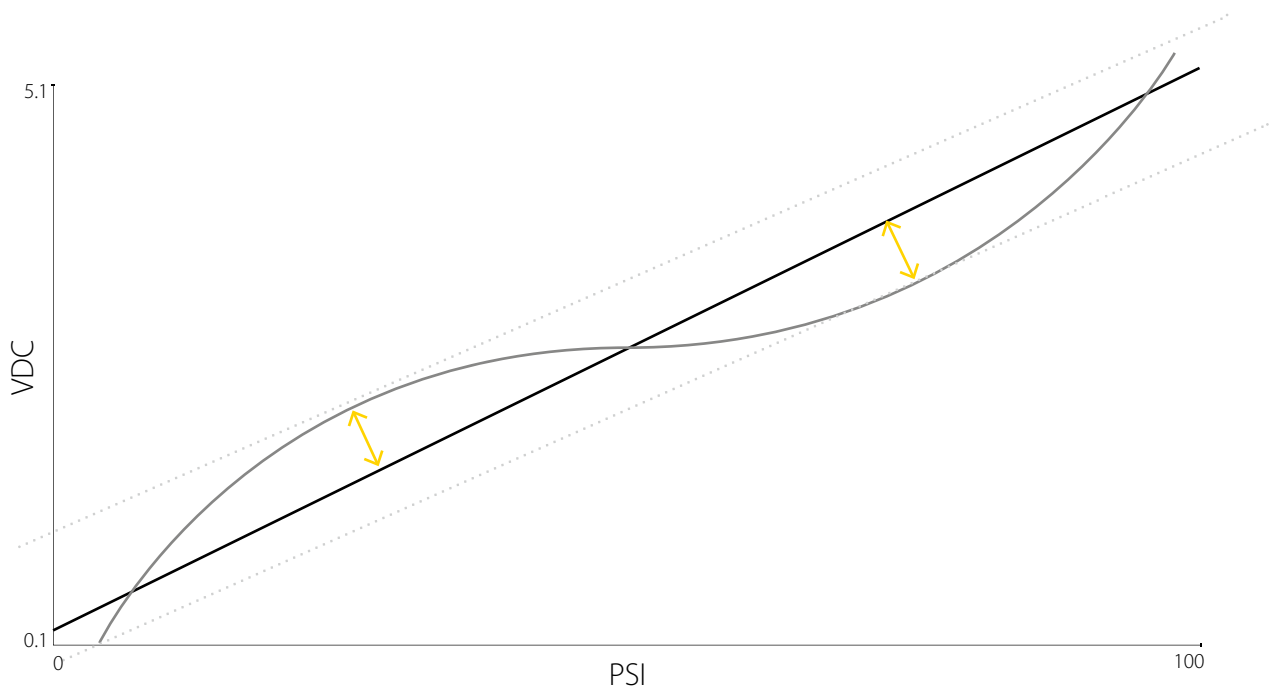

**Best Fit Straight Line (BFSL)** is the relationship of the plotted characteristics of the pressure cell and a calculated straight line that does not pass through the end points. The linear line is placed in the center of the accuracy deviation to minimize error.

## Measuring Liquid Level With A Pressure Sensor

There are multiple ways to use pressure sensors in liquid level measuring applications. One method involves a sensor that is submerged in the media and is mounted inside of the tank. The sensor may or may not be in contact with the bottom of the tank; in some instances it is problematic for the sensor to be on the bottom of the tank due to debris. In a static tank it may not be necessary to support the sensor, but in a turbulent tank it may be beneficial to use a conduit or a strain relief to control the orientation and stress on the sensor and its cable.

Another way to use pressure in a level application is to place the sensor on the bottom of the exterior of the tank via plumbing. The sensor will have to be mounted in the lowest possible position to reduce the amount of offset that cannot be seen by the sensor. This type of configuration is common in the food/beverage industry, where consumables cannot be contaminated, and also reduces the amount of contact between the media and the sensor.

## Fluid Column Height In PSI

Height of tank in feet/2.31 X Specific Gravity of the fluid = PSI

The formula above is an aid for proper sensor sizing when looking for a media column height.

The formula above can also work to use the pressure sensor to read the volume of a tank. With the formula below you can use the height, width and depth of a tank to get the volume.

There are 231 cubic inches (0.133681 cubic feet) in one US liquid gallon (Fig. 4).



Fig. 4

## FORMULAS

Pressure Sensor Sizing

$$16 \text{ FT} / 2.31 \cdot 1 = \text{PSI}$$

$$16 \text{ FT} / 2.31 \cdot 1 = 6.93 \text{ PSI}$$

15 PSIG sensor is chosen

PT15PSIG-1003-I2-H1143

Using Pressure To Detect Volume

$$(3.14 \times r^2) \times \text{height of tank}$$

$$(3.14 \times 3 \text{ FT}^2) \times 16 \text{ FT} = 4071.5 \text{ FT}^3$$

$$452.4 \text{ FT}^3 / 0.133681 = 3384 \text{ Gallons (full tank)}$$

$$(3.14 \times 3 \text{ FT}^2) \times 12 \text{ FT} = 339.4 \text{ FT}^3$$

$$339.4 \text{ FT}^3 / 0.133681 = 2538.9 \text{ Gallons}$$

(with 12 FT water column height)



**Address:-** Sector 130, Shastri Garhi Shahpur, Noida, Uttar Pradesh- 201304

**Mob:-** +91 - 981187005, 9711966037, 9711966066

**Email:-** seereba@seereba.com, sales@seereba.com

**Website:-** www.seereba.com

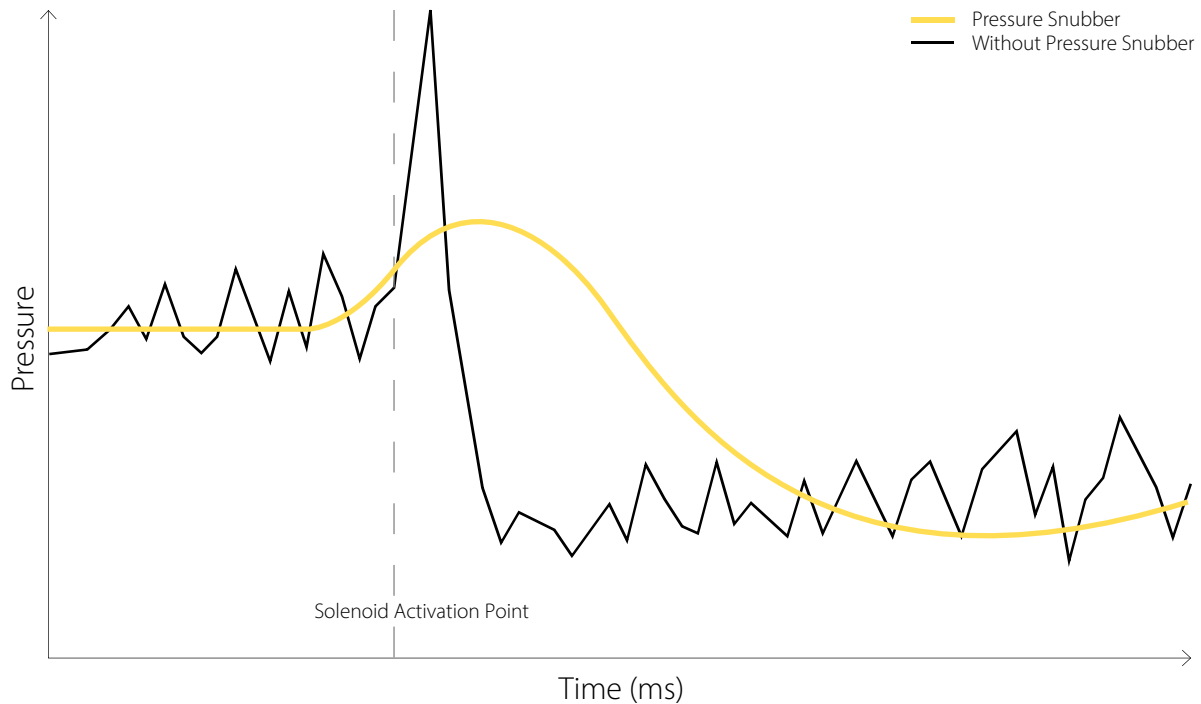

Fig. 5

## Over Pressure And Burst Pressure

Each measuring cell is designed for a specific measuring range. This determines the thickness of the measuring cell. When a measuring cell is pressurized over its rated pressure range, it can cause zero/span shifts or damage to the cell. There are two specifications given to this:

**Permissible Overpressure** is the amount of pressure over the range that may cause the sensors zero/span point to shift, but will not cause the cell to burst.

**Burst Pressure** is typically greater than the over pressure and is the maximum pressure the cell can handle before the cell bursts or ruptures. Once the cell ruptures, you may see the media leaking from the sensors reference vent.

## \*Pressure Spikes And Transients

Pressure sensors will undoubtedly be subject to pressure spikes or transients during operation. This generally occurs when a positive displacement pump is energized

with no soft start, or when a valve is opened and closed quickly (i.e., a solenoid valve). Water hammer is also a very common cause of pressure spikes. Below we have highlighted some common ways to lessen the effects of pressure spikes or transients (Fig. 5).

**Pressure Snubber** is a process fitting that would go onto the process connection of the pressure sensor and is either a sintered metal/ceramic screen or an orifice. This helps to control the amount of volume that can be moved to the pressure cell and isolates the spike before the pressure cell.

**Pulsation Dampener** is a device that goes on the process line that the sensor is connected to. This works by having a pressurized air gap that is sealed from the process media by a membrane. The air gap will act as a shock absorber for the pressure cell.

**Pulsation Hose** is a pressure rated hose that is made to flex with pressure spikes to help relieve some of the stress the sensor would see. These can either be placed in between the sensor and the process pipe or can be mounted on the process line that the pressure sensor is mounted to.

## Calibration NIST Certificates

Pressure sensors do not generally come with a calibration certificate, although it is possible to receive a certificate when ordering any pressure sensor from Turck. If a /S1802 is added to the end of a pressure sensor part number (i.e., PT30PSIG-2003-I2-H1141/S1802) this sensor will come with a 5 point NIST traceable calibration certificate. This certificate tells you the deviation and consistency of the transmitters output from the factory. The calibration certificates are compliant to the old Z540 standard as well as the newer Z540.3. It will be up to the purchaser to determine the calibration intervals and to find a calibration facility to keep the sensors certificate up to date.

## \*\*High Temperature Applications

Using a sensor in applications where the media temperature is higher than the sensor rating may cause sensor failure or a decrease in sensor performance. This is not recommended. Below are some common ways to mitigate the amount of heat transferred by the media (Fig.6).

**Siphon Tube** is a tube that is generally bent in a 180° or 360° rotation. This works by not allowing fresh heated fluid to move through the pipe, creating a cool spot.

**Stand Pipe** is a length of pipe used as an insulation barrier. The longer the pipe the more heat is lost through the stand pipe and does not reach the sensor.

**Auxiliary Hose** goes between the sensor and the process pipe much like a stand pipe would, only it is a pliable hose that will have to be rigidly mounted.

**Heat Exchanger** is a device that generally has heat sink fins on it. The fins help wick away the heat in the heat exchanger to the ambient air.

**Diaphragms** are generally not used as a way to protect the sensor from heat, and due to not having heat dissipation charts the overall effectiveness is unknown. Diaphragms are large pieces of metal that provide a barrier between the sensor and media and will help mitigate some of the heat that would be seen by the sensor.

PCS - G 1/4A4 Heat Exchanger

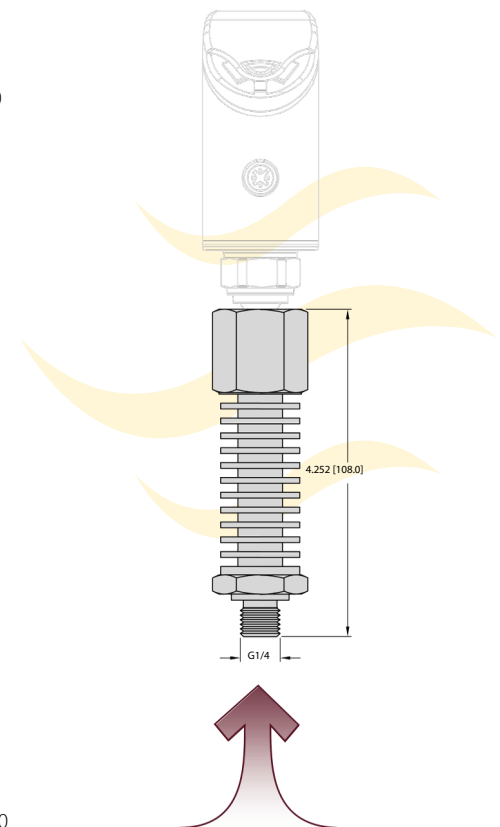
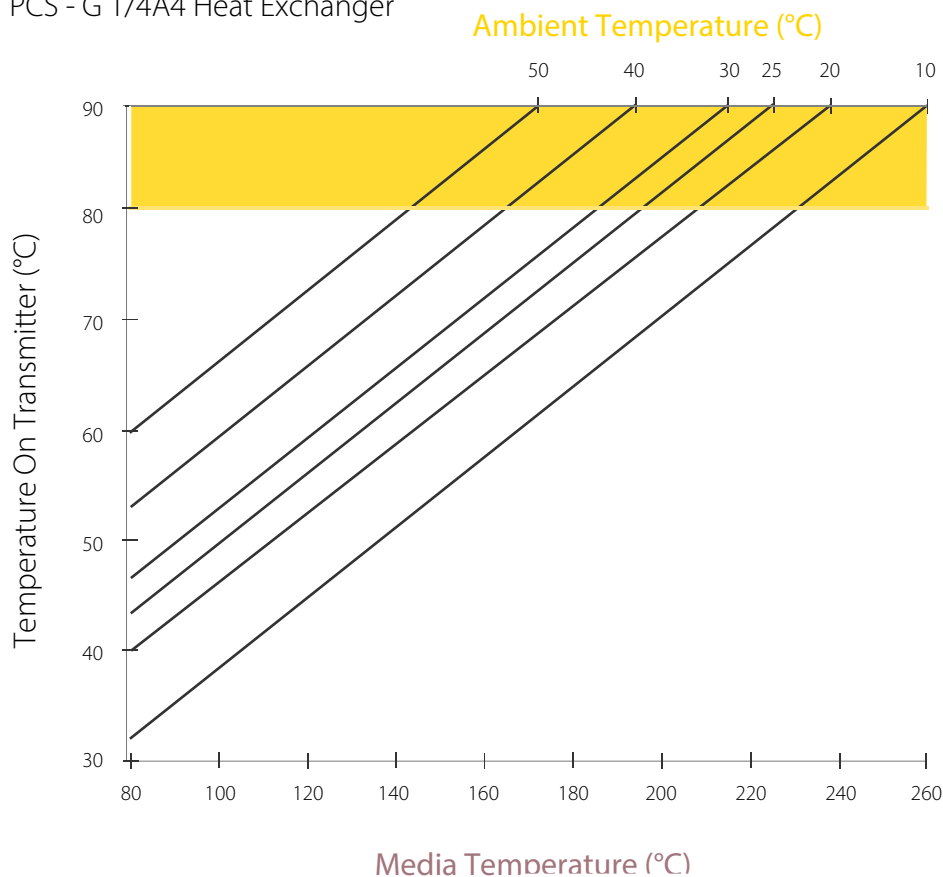

**Address:-** Sector 130, Shastri Garhi Shahpur, Noida, Uttar Pradesh- 201304

**Mob:-** +91 - 981187005, 9711966037, 9711966066

**Email:-** seereba@seereba.com, sales@seereba.com

**Website:-** www.seereba.com

## Process Connections

The process side of the sensor is the area in which the media comes in contact with the measuring cell. This is where the connection is made from the system to the transmitter. There are many ways to make this connection. The most common are threaded connections, and below are common types of threaded connections used. For non-threaded connections, see the diaphragm sections for alternatives.

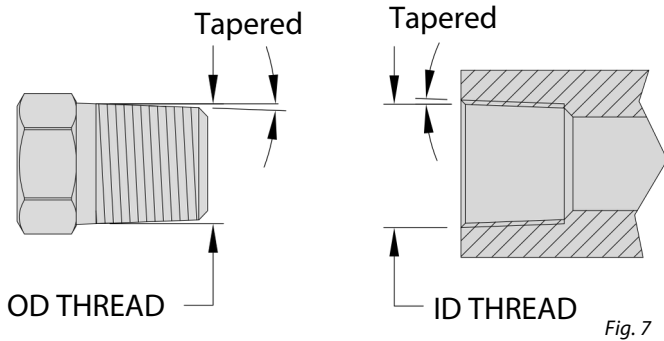

**National Pipe Taper (NPT)** is the most common thread used in the US. There are different types of NPT threads, but all are tapered for sealing, while some require the use of a thread sealant. Others, such as NPTF, are a dry seal taper thread that seals by deforming the threads (Fig. 7).

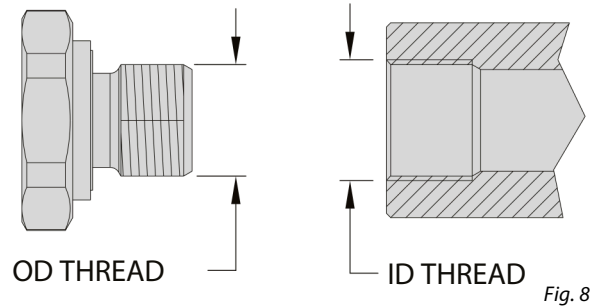

**British Standard Pipe Parallel (BSPP or G)** is a common thread in Europe. This is a straight thread that is sealed by the use of a gasket or O-ring (Fig. 8).

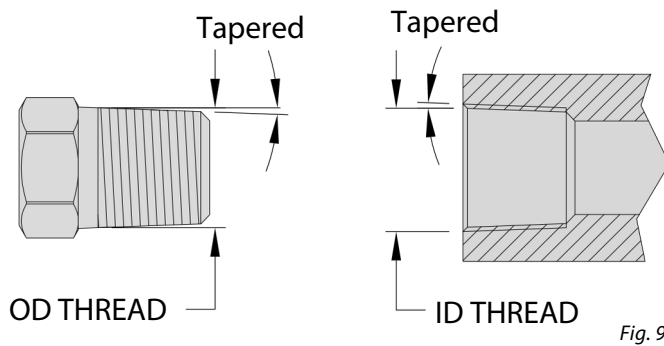

**British Standard Pipe Tapered (BSPT or R)** is a common thread in Europe. This is a tapered thread like NPT but the pitch is different. The threaded diameter is close but not identical and not interchangeable. The seal is formed by deforming the threads much like NPTF (Fig. 9).

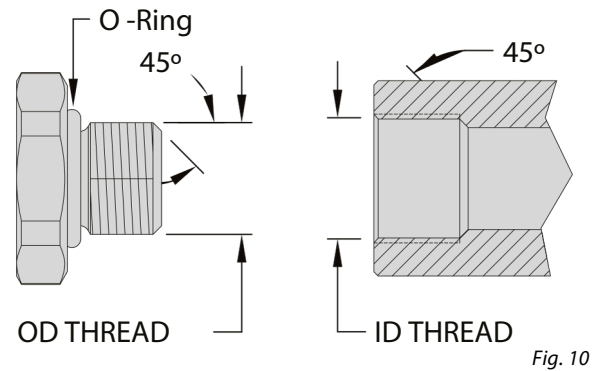

**Society of Automotive Engineers O-ring Boss (SAE ORB)** is used in high pressure hydraulic systems. It has a straight thread that is sealed by compressing an O-ring on the male thread to a chamber on the female thread that guides the O-ring and applies the correct compression (Fig. 10).

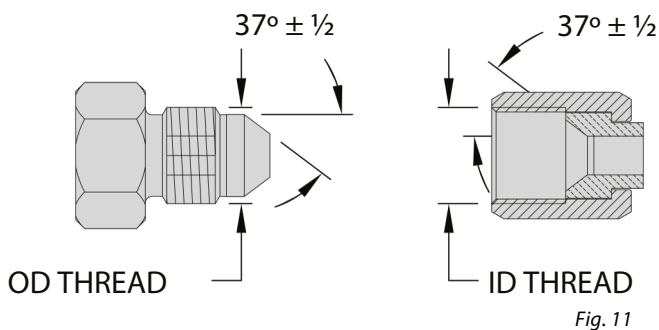

**Joint Industrial Commission (JIC) 37° Flare** is a very common fluid power connection. The male half has a flare and the female half has a cone, both with a 37° seat. The seal is established by the flare and cone compressing together (Fig. 11).

# Glossary Of Terms



**Address:-** Sector 130, Shastri Garhi Shahpur, Noida, Uttar Pradesh- 201304  
**Mob:-** +91 - 981187005, 9711966037, 9711966066  
**Email:-** seereba@seereba.com, sales@seereba.com  
**Website:-** www.seereba.com

Term	Definition
3A	3A is an independent, not-for-profit corporation dedicated to advancing hygienic equipment design for the food, beverage, and pharmaceutical industries.
4 - 20 mA Loop	In industrial process control, analog 4 - 20 mA current loops are commonly used for electronic signaling, with the two values of 4 & 20 mA representing 0 - 100% of the range of measurement or control.
Absolute Pressure	Absolute pressure is zero-referenced against a perfect vacuum, so it is equal to gauge pressure plus atmospheric pressure. Negative signs are usually omitted.
Accuracy	The maximum deviation from the theoretical linear line between a sensor's zero and span output seen by the characteristic curve observed in testing under specified conditions and by a specified procedure. Accuracy must include Hysteresis, Non-Repeatability, and Non-Linearity.
Ambient Conditions	Typically include temperature, humidity, and air pressure.
Atmospheric Pressure	The amount of pressure produced by the weight of the atmosphere. This can change relative to elevation from sea level as well as shifts in barometric pressure.
Auxiliary Hose	A pliable hose that goes in between the sensor and process pipe an insulator and a place for the heat to dissipate.
Bar	A metric unit of pressure. It is defined as exactly equal to 100,000 Pa, which is slightly less than the current average atmospheric pressure on Earth at sea level.
Barometric Pressure	See <i>Atmospheric Pressure</i> .
Best Fit Straight Line (BSFL)	The relationship of the plotted characteristics of the pressure cell and a calculated straight line that does not pass through the end points. The linear line is placed in the center of the accuracy deviation to minimize error.
British Standard Pipe Parallel (BSPP or G)	A common thread in Europe. This is a straight thread that is sealed by the use of a gasket or O-ring.
British Standard Pipe Tapered (BSPT or R)	A common thread in Europe. This is a tapered thread like NPT but the pitch is different. The threaded diameter is close but not identical and not interchangeable. The seal is formed by deforming the threads much like NPTF.
Burst Pressure	Typically greater than the over pressure and is the maximum pressure the cell can handle before the cell bursts or ruptures. Once the cell ruptures, you may see the media leaking from the sensors reference vent.



**Address:-** Sector 130, Shastri Garhi Shahpur, Noida,  
Uttar Pradesh- 201304  
**Mob:-** +91 - 981187005, 9711966037, 9711966066  
**Email:-** seereba@seereba.com, sales@seereba.com  
**Website:-** www.seereba.com

Term	Definition
Capillary Tube	See <i>Auxiliary Hose</i> .
Clean In Place (CIP)	A method of cleaning the interior surfaces of pipes, vessels, process equipment, filters, and associated fittings, without disassembly. Commonly used in food and pharmaceutical processes.
Compensated Range	The temperature range in which the accuracy holds true without any added deviations.
Compound Pressure	A measurement of both positive and negative (vacuum) pressures.
Diaphragm Seal	A device that is placed on the process side of the sensor that can be made of different materials to allow for greater chemical compatibility. Also called an isolator.
Differential Pressure	A sensor that uses two measurement cells; one for high pressure and one for low pressure, and calculates the difference between them.
Dynamic Pressure	Continually changing pressure, or a pressure that may not be stable or subject to change under normal operation.
Full Scale (FS)	The relationship of the plotted characteristics of the pressure cell and a calculated straight line that starts and stops at the cell's end points. The greatest deviation away from the linear line would be the accuracy deviation.
"G" Process Connection	See <i>British Standard Pipe Parallel (BSPP or G)</i> .
Gauge Pressure	Gauge pressure is zero-referenced against ambient air pressure, so it is equal to absolute pressure minus atmospheric pressure.
Head Pressure	Is the pressure caused by the weight of the fluid on a specific area.
Heat Exchanger	A device for transferring heat from one medium to another.
Hydrophobic	A material that will repel the mass of water.
Hysteresis	The maximum difference in sensor output at a pressure when that pressure is first approached with pressure increasing, and then approached with pressure decreasing during a full span pressure cycle.



**Address:-** Sector 130, Shastri Garhi Shahpur, Noida, Uttar Pradesh- 201304  
**Mob:-** +91 - 981187005, 9711966037, 9711966066  
**Email:-** seereba@seereba.com, sales@seereba.com  
**Website:-** www.seereba.com

Term	Definition
kPa	Kilopascal, or 1,000 newtons per square meter.
JIC	A very common fluid power connection. The male half has a flare and the female half has a cone, both with a 37° seat. The seal is established by the flare and cone compressing together.
LHR	Linearity, Hysteresis, and Repeatability; a common call-out for accuracy.
Linearity	Where inconsistency comes in. There are two methods typically used: <b>Best Fit Straight Line (BFSL)</b> , and <b>Full Scale (FS)</b> or Terminal Point. It is the amount of error that exists between a sensor output and a linear line.
Long Term Stability	The degree of uniformity over time. Environmental conditions can change such as supply voltage load and temperature.
mPa	Mega Pascal, equal to one newton per square meter.
NIST Certificate	A third party certificate of calibration. Done to the standards of the National Institute of Standards and Technology.
National Pipe Taper (NPT)	The most common thread used in the US. There are different types of NPT threads, but all are tapered for sealing. Some require the use of a thread sealant.
O-ring Face Seal (ORFD)	This connection offers very good leak control due to the O-ring seating on a flat surface. The male portion has straight threads with an O-ring on the face of the connection, while the female portion has a large flat spot for the O-ring to seat.
Oxygen Clean	The verifiable absence of particulate, fiber, oil, grease, and other contaminants.
Permissible Overpressure	The amount of pressure over the range that may cause the sensors zero/span point to shift but will not cause the cell to burst.
PG	Abbreviation for PSIG.
Pressure Sensor	Can work as either as a pressure transmitter/transducer and/or a pressure switch.
Pressure Snubbers	A process fitting that would go onto the process connection of the pressure sensor and is either a sintered metal/ceramic screen or an orifice. This helps to control the amount of volume that can be moved to the pressure cell and isolated the spike before the pressure cell.



**Address:-** Sector 130, Shastri Garhi Shahpur, Noida,  
Uttar Pradesh- 201304  
**Mob:-** +91 - 981187005, 9711966037, 9711966066  
**Email:-** seereba@seereba.com, sales@seereba.com  
**Website:-** www.seereba.com

Term	Definition
<b>Pressure Spike, or Transient</b>	Refers to any pressure wave that is short lived (i.e., not static pressure or pressure differential due to friction/minor loss in flow). The most common occurrence of this is called water hammer.
<b>Pressure Switch</b>	Converts mechanical force of gases or liquids to an electrical signal. The electrical signal is discrete. Normally open or closed contact that switches state when the pressure rises above or falls below the set point.
<b>Pressure Transmitter / Pressure Transducer</b>	Converts mechanical force of gases or liquids to an electrical signal. The electrical signal is an analog current or voltage of a specified value.
<b>Process Connections</b>	The process side of the sensor is the area in which the media comes in contact with the measuring cell. This is where the connection is made from the system to the transmitter.
<b>Proof Pressure</b>	See <i>Permissible Overpressure</i> .
<b>PSIA</b>	Unit of measure; Pounds per Square Inch, with a reference of Absolute pressure.
<b>PSIG</b>	Unit of measure; Pounds per Square Inch, with a reference of Gauge pressure.
<b>PSIS</b>	Unit of measure; Pounds per Square Inch, with a reference of Sealed pressure.
<b>PSIV</b>	Unit of measure; Pounds per Square Inch, with a reference of Gauge pressure and a compound range.
<b>Pulsation Dampener</b>	A device that goes on the process line that the sensor is connected to. This works by having a pressurized air gap that is sealed from the process media by a membrane. The air gap will act as a shock absorber for the pressure cell.
<b>"R" Process Connection</b>	See <i>British Standard Pipe Tapered (BSPT or R)</i> .
<b>Ratiometric</b>	An output voltage that is a ratio of 10 - 90% of the supply voltage (i.e., 5 VDC regulated supply 0.5 - 4.5 VDC output).
<b>Relative Pressure</b>	The pressure caused by the weight of air in the atmosphere.
<b>Repeatability</b>	The maximum difference in output when the same pressure is applied, consecutively, under the same conditions and approaching from the same direction.



**Address:-** Sector 130, Shastri Garhi Shahpur, Noida, Uttar Pradesh- 201304  
**Mob:-** +91 - 981187005, 9711966037, 9711966066  
**Email:-** seereba@seereba.com, sales@seereba.com  
**Website:-** www.seereba.com

Term	Definition
Resolution	The smallest unit that can be reliably measured, considering accuracy.
Response Time	How fast the output changes with the mechanical pressure change in the system.
SAE-ORB	Used in high pressure hydraulic systems. It has a straight thread that is sealed by compressing an O-ring on the male thread to a chamber on the female thread that guides the O-ring and applies the correct compression.
Sealed Pressure	The reference of the pressure sensor is sealed when manufactured. This may induce a small error when used in different elevation from where it was manufactured.
Siphon Tube	This is a tube that is generally bent in a 180° or 360° rotation. This works by not allowing fresh heated fluid to move through the pipe creating a cool spot.
Span	The distance from the zero point to the end point.
Span Shift	The deviation of the analog end point.
Stand Pipe	This is a length of pipe used as an insulation barrier. The longer the pipe the more heat is lost through the stand pipe and does not reach the sensor.
Static Pressure	The pressure of a fluid on a body when the body is at rest relative to the fluid.
Thermal Shift	The deviation of the zero/end points that are caused by temperature shifts.
Total Error Band	Accounts for accuracy, sensor stability, thermal effect on zero/span, and zero/span shift. This will take into account all of the potential errors that may be induced on the sensor.
Water Column (W.C.)	The amount of pressure produced by a column of liquid.
Water Hammer	A pressure surge or wave caused when a fluid (usually a liquid but sometimes a gas) in motion is forced to stop or change direction suddenly.
Wetted Materials	The materials that come into contact with the media.
Zero Shift	A deviation of the zero point.





**Address:-** Sector 130, Shastri Garhi Shahpur, Noida,  
Uttar Pradesh- 201304

**Mob:-** +91 - 981187005, 9711966037, 9711966066

**Email:-** seereba@seereba.com, sales@seereba.com

**Website:-** www.seereba.com

Turck Inc. sells its products through Authorized Distributors. These distributors provide our customers with technical support, service, and local stock. Turck distributors are located nationwide – including all major metropolitan marketing areas.

For Application Assistance or for the location of your nearest Turck distributor, call:

1-800-544-7769

Specifications in this manual are subject to change without notice. Turck also reserves the right to make modifications and makes no guarantee of the accuracy of the information contained herein.

Literature and Media questions or concerns?  
Contact Turck USA Marketing – tusa.marketing@turck.com

# TURCK



**Address:-** Sector 130, Shastri Garhi Shahpur, Noida,  
Uttar Pradesh- 201304

**Mob:-** +91 - 981187005, 9711966037, 9711966066

**Email:-** seereba@seereba.com, sales@seereba.com

**Website:-** www.seereba.com

30 subsidiaries and over  
60 representations worldwide!

Printed in USA

©2021 by Turck Inc. All rights reserved. No part of the  
publication may be reproduced without written permission.

B1053 D 2/21

[www.turck.com](http://www.turck.com)